

# FACULTY OF MECHANICAL ENGINEERING

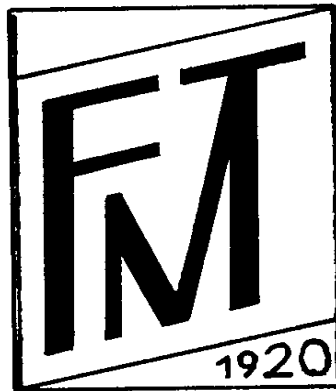

**Bd. Mihai Viteazul, Nr. 1**  
**300222 – Timișoara, Romania**  
**Tel: +40-256-403521**  
**Fax: +40-256-403523**

**E-mail: [decan@mec.upt.ro](mailto:decan@mec.upt.ro)**  
**Web: [www.mec.upt.ro](http://www.mec.upt.ro)**



# MEDICAL ENGINEERING RESEARCH CENTRE

## GENERAL PRESENTATION

The *Medical Engineering Research Centre* was recognized as Research Centre in “Politehnica” University of Timisoara in 2011 year, representing a development of the CMPICSU Research Centre.

The research team joins researchers, teachers and PhD students having different competences – mechanical engineering, computer science, mathematics, and physiotherapy – from “Politehnica” University of Timisoara.

The *Centre for Modeling the Prosthetic Appliances and Surgical Operations on Human Skeleton* (CMPICSU) was structured as a Multiple User Research Centre (MURC), co-ordinated by Professor Doina Dragulescu. The CMPICSU partners in Timisoara were University of Medicine and Pharmacy “Victor Babes” Timisoara, Hospital of Traumatology and Orthopedy No 1 Timisoara, and Municipal Hospital of Oro-Maxillo-Facial Surgery.

The *Medical Engineering Research Centre* is strongly involved in the Bachelor - *Medical Engineering* specialization, Masters - *Implants, Intelligent Prostheses and Biomechanical Evaluation* and Doctoral Programs in *Medical Engineering*, within the “Politehnica” University of Timișoara.

## BRIEF HISTORY

- CMPICSU Research Centre was founded in 2002, based on Multiple User Research Centres (MURC) Program;
- During 2002-2006 other founds were attracted and new laboratories were created – LOPIFO Laboratory for implant manufacturing – authorized by the Health Ministry, CIDUCOS Laboratory for testing of medical devices – accredited by RENAR, and Motion analysis Laboratory;
- During September 2006 – December 2008 a new important project *Platform of implantology, intelligent prosthetics and biomechanical rehabilitation* was developed, and new laboratories were created: Manufacturing Laboratory – Rapid Prototyping Fabrication, Manufacturing Laboratory – CNC Machining and EDM Fabrication, Medical Investigation Laboratory.

## MISSION

The Medical Engineering Research Centre has been created in order to integrate the scientific research results in the field of Medical Engineering. Thus,

the *Medical Engineering Research Centre* represents a connecting factor, oriented towards interdisciplinary research and education.

The *Medical Engineering Research Centre* is designed to be a union place for research – education – production – services to both interdisciplinary formation of specialists in Medical Engineering field and release integrated solutions of diagnosis, prosthetics, mobility rehabilitation and modern technologies for medical devices manufacturing.

The main aim of the research centre is to integrate its activities in the European Research Area in the field of Medical Engineering.

## RESEARCH FIELDS

- Biomechanics;
- Implantology and prosthetics;
- Modern technologies for manufacturing;
- Testing of medical devices;
- Acquisition and processing of medical signals and images;
- Robotics.

## KEYWORDS

Motion analysis, Plantar pressure distribution, Biological structure modeling, Medical imaging, 3D reconstruction, Dental and orthopedic implants, Prostheses, Biocompatible materials, Rapid prototyping, Manufacturing of medical devices components.

## ACTIVITIES

- *Fundamental and applied research in Biomechanics, biomechanical modeling of human locomotor apparatus;*
- *Motion analysis of patients having different deficiencies and animals in order to evaluate the disorder or the rehabilitation process based on biomechanical principles;*
- *Motion analysis of sportsmen in order to evaluate and improve their performances based on biomechanical principles;*
- *Static and dynamic study of plantar pressure distribution both for normal subjects and patients having different disorders;*
- *Modeling and numerical analysis of stress and strain distributions in bone structures, implants, assembly of bone/implants and prosthetic components;*
- *Design of dental and orthopedic implants for both human patients and animals;*









- *Design and manufacturing of prosthetic devices;*
- *Image acquisition and processing, 3D reconstruction of biological structures based on CT technique and specialized software, in order to develop a complex database for different categories of skeleton deficiencies and to produce customized implants;*
- *Development of appropriate technologies (including rapid prototyping, CNC machining, EDM technologies) to manufacture implants and prosthetic devices using biocompatible materials.*



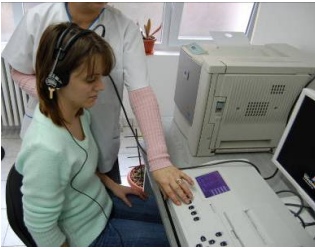

### RESEARCH RESULTS

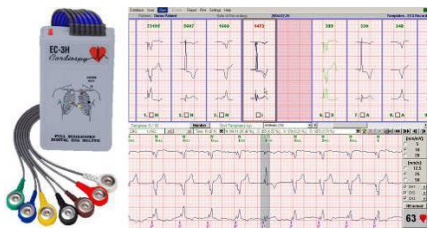



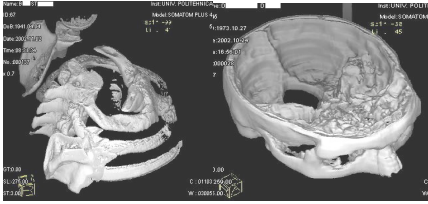

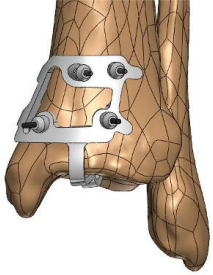
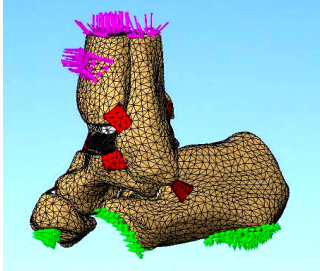
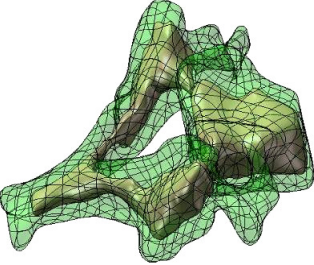
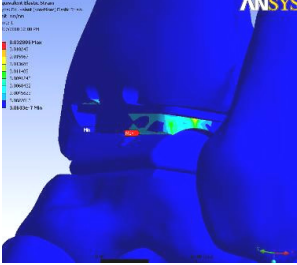

- *Biological structures reconstruction based on computed tomography, MIMICS software and CAD techniques – different bone structures of human and animal skeletons – allowing different mechanical properties;*
- *FE analysis of bone structures, implants, bone - implant systems, and prosthetic components;*
- *Experimental motion analysis and dynamic plantar pressure distribution determination in order to evaluate a certain disorder and its influence on the patient mobility;*
- *Assessment of cervical and lumbar spine mobility and posture;*
- *Assessment of spatio-temporal and kinematic parameters in treadmill-based gait;*
- *Experimental kinematic analysis of a group of dogs, in order to obtain a pattern of the dog movement (healthy, having induced defects and recovered) and use the results as reference data to evaluate the influence of the limb skeleton defects (natural or induced by humeral head OCD on the right front leg joints) on the kinematic parameters, and evaluate the rehabilitation process after surgery;*
- *Determination the mechanical properties of canine bones such as femur, tibia and humerus from adult dogs using compression, torsion and bending tests and developing a data base of mechanical strength of canine bones;*
- *Conception, design, modeling, and theoretical and experimental analysis of implants for upper and lower limb, cervical and lumbar spine, and a low cost upper limb prosthesis.*

### LABORATORIES

1. *Motion Analysis Laboratory:* Zebris measuring system for gait analysis and plantar pressure distribution determination, ARIEL Performance Analysis System (APAS) for motion analysis, and different exercise devices (treadmill, upright bike body, and band massage device).
2. *Modeling and design laboratory:* equipped with professional hardware (20 Intel core workstations for design and analysis of prosthetic devices and implants; projector with hookup to laptop, instructor's computer; whiteboard) where professional software is installed.
3. *Medical Imaging Laboratory:* computed tomography system (SIEMENS SOMATOM Plus 4 Power Computer Tomograph), electrosomatograph DDFAO system (computer-assisted screening and functional diagnosis), echocardiograph ACUSON CV70™ (cardiovascular ultrasound system).
4. *Medical investigations Laboratory:* is a useful tool that explores many practices and various situations arising in usual medical investigations: vascular Doppler, pulse oximeter, holter system, audiometer, electrocardiograph, kit for measuring the human physiological parameters.
5. *Manufacturing Laboratory – CNC Machining and EDM Fabrication:* fabrication under precision and repeatability conditions of implants and medical devices. The conditions are provided by the computer numerical control of each machine.
6. *Manufacturing Laboratory – Rapid Prototyping Fabrication:* prototyping machines serve both in model validation and rapid fabrication. Tools and ready to use parts are possible to build in both metals and plastic materials.
7. *Manufacturing Laboratory for implant devices, orthoses and prosthetic devices* LOPIFO: classical machining equipments are used in prototype developing of prosthetic devices and medical instrumentation;
8. *Testing Laboratory* CIDUCOS: corrosion test, hardness test, mass and density determination, metallographic analyses, mechanical tests, spectrometry test.
9. *Multimedia Room:* supports the teaching process and allows the students to practice their presentation skills (video projector with hookup to laptop, whiteboard, wireless network, video conference system).

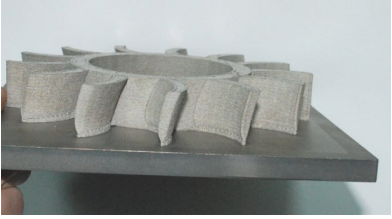
<p><b>Motion analysis Laboratory</b></p>			<p>Zebris measuring system. Movement analysis on treadmill and bicycle</p>
			<p>Zebris measuring system. Assessment of cervical spine mobility</p> <p>Zebris measuring system. Measurement of plantar pressure distribution</p>
			<p>APAS sequence from motion analysis</p>
	<p><b>Medical investigation Laboratory</b></p>		
		<p>Audiometric test</p> <p>Pulse oximeter device</p>	
		<p>Holter system</p> <p>Blood pressure measurement</p>	

<b>Medical imaging Laboratory</b>		
	Somatom Plus 4 Power Computer tomography system	3D reconstructions using the CT software
		
	Electrosomatograph DDFAO system	Echocardiograph ACUSON CV70™
<b>Modeling &amp; Design Laboratory</b>		
	Medical imaging class	
		
	Assembly of tibia and surgical guide	Mesh, load and constraints of ankle model
		
	Model of multipart cervical vertebra	FEA results for maximum elastic strain in knee prosthesis

<p><b>Manufacturing Laboratory - CNC Machining and EDM Fabrication</b></p>		
	<p>Dental implants fabrication on 5 axis CNC machining center</p>	<p>Artificial disk fabrication on 3axis CNC milling machine</p>
		
	<p>Maxillo-facial plate implant fabrication on wire EDM machine</p>	<p>Orthopedic /dental implants</p>
<p><b>Manufacturing Laboratory – Rapid Prototyping Fabrication</b></p>		
	<p>Metal Powder Arcam S12 machine – metal substitution plate fabrication</p>	<p>CoCr impeller built on Arcam S12 machine</p>
		
<p>Plastic powder EOS Formiga P100 machine – plastic substitution elements fabrication</p>	<p>Models and microstructure of hip implants made of Poliamide PA 2200</p>	
<p><b>Multimedia Room</b></p>		
	<p>Medical Engineering students</p>	

## PUBLICATIONS

## PAPERS IN JOURNALS

1. M. Toth-Taşcău, D.I. Stoia, *Analysis of dimensional accuracy of two models of customized hip prostheses made of Polyamide powder by Selective Laser Melting Technology*, Optoelectronics and Advanced Materials – Rapid Communications, Vol. 5, No. 12, 2011, pp. 1256 – 1263, ISSN 1842-6573.
2. I. Dumitru, L. Kun, M. Dreucean, K. Menyhardt, *The equivalent stress concept in multiaxial fatigue*, Journal of Engineering Studies and Research, vol.17, 2011, pp. 53-62, ISSN 20687559.
3. B. Almajan-Guta, C. Avram, A. Rusu, O. Cluci, V. Almajan-Guta, *Efficiency of aerobic training and incentive therapy in teenagers with cystic fibrosis*, Acta Paediatrica, Special Issue: Abstracts from the third Excellence in Paediatrics Conference, 30 November - 3 December 2011, Istanbul, Turkey, Volume 100, Issue Supplement s463, December 2011, pp. 79, ISSN 0803-5253.
4. B. Almajan-Guta, A. Rusu, C. Avram, V. Almajan-Guta, *Individualized training, chest physiotherapy and incentive training in cystic fibrosis patients*, Romanian Sports Medicine Journal, Vol VII. No.3 (27), 2011, pp. 1648-1653, ISSN 1841-0162.
5. C. Avram, M. Oravitan, A. Nagel, B. Almajan-Guta, L. Hoble, A. Rusu, *Testing and training the strength, power and complex reactions in rugby players*, Palestrica mileniului III - Civilizatie si sport, Vol. 12, No.3, 2011, pp. 236-239, pISSN 1582-1943.
6. C. Avram, M. Oravitan, M. Domokos, B. Almajan-Guta, L. Hoble, C. Oancea, *Supervised lifestyle intervention effectiveness in reducing cardiometabolic risk of patients with metabolic syndrome*, Medicine in evolution, Vol XVII, No.3, 2011, pp. 176-186, ISSN 2065-376X.
7. Numerical Analysis and Applied Mathematics ICNAAM 2011, 19-25 September 2011, AIP Conference Proceedings, Volume 1389, Halkidiki, Greece, pp. 1305-1309, ISSN 0094-243X.
3. M. Toth-Taşcău, F. Pater, D.I. Stoia, K. Menyhardt, Ş. Roşu, L. Rusu, C. Vigaru, *Using of Bezier interpolation in 3D reconstruction of human femur bone*, International Conference on Numerical Analysis and Applied Mathematics ICNAAM 2011, 19-25 September 2011, AIP Conference Proceedings, Volume 1389, Halkidiki, Greece, pp. 1309-1312, ISSN 0094-243X.
4. M. Toth-Taşcău, D.I. Stoia, *Influence of treadmill velocity on gait characteristics – case study of a patient with ankle instability*, International Conference on Advancements of Medicine and Health Care through Technology MediTech 2011, 29 August - 2 September, IFMBE Proceedings Series, pp. 372-375, ISBN 978-3-642-22585-7.
5. D.I. Stoia, M. Toth-Taşcău, *Comparison of treadmill-based and overground gait analysis*, International Conference on Advancements of Medicine and Health Care through Technology MediTech 2011, 29 August - 2 September, IFMBE Proceedings Series, pp. 368-371, ISBN 978-3-642-22585-7.
6. M. Toth-Taşcău, C. Saftescu-Jescu, D. Bugariu, L. Bereteu, *Determining the center of pressure trajectories during lumbar spine flexion*, International Conference on Advancements of Medicine and Health Care through Technology MediTech 2011, 29 August - 2 September, IFMBE Proceedings Series, pp. 384-387, ISBN 978-3-642-22585-7.
7. M. Toth-Taşcău, M. Krepelka, *Biomechanical analysis of long-stem hip prosthesis*, 11th International Conference "Research and Development in Mechanical Industry" – RaDMI 2011, Sokobanja, Serbia, 15 – 18 September, pp. 1277-1282, ISBN 978-86-6075-028-2.
8. M. Toth-Taşcău, L. Rusu, F. Balanean, C. Toader-Pasti, *Mechanical tests of the stabilization system for radius fractures*, 11th International Conference "Research and Development in Mechanical Industry" – RaDMI 2011, Sokobanja, Serbia, 15 – 18 September, pp. 1283-1287, ISBN 978-86-6075-028-2.
9. D. Bugariu, O.M. Pasca, M. Toth-Taşcău, C. Saftescu-Jescu, *Study of flexion-extension movement in knee and ankle joints during cycling*, 11th International Conference "Research and Development in Mechanical Industry" – RaDMI 2011, Sokobanja, Serbia, 15 – 18 September, pp. 1097-1102, ISBN 978-86-6075-028-2.

## PAPERS IN INTERNATIONAL PROCEEDINGS

1. M. Toth-Taşcău, F. Pater, D.I. Stoia, K. Menyhardt, Ş. Roşu, L. Rusu, C. Vigaru, *A Mathematical Model of the Cervical Spine Movement*, International Conference on Numerical Analysis and Applied Mathematics ICNAAM 2011, 19-25 September 2011, AIP Conference Proceedings, Volume 1389, Halkidiki, Greece, pp. 1301-1304, ISSN 0094-243X.
2. M. Toth-Taşcău, F. Pater, D.I. Stoia, K. Menyhardt, Ş. Roşu, L. Rusu, C. Vigaru, *Inverse kinematic analysis of human hand thumb model*, International Conference on



10. R. Nagy, K. Menyhardt, *Kinematics of an upper limb prosthesis model*, 11th International Conference "Research and Development in Mechanical Industry" – RaDMI 2011, Sokobanja, Serbia, 15 – 18 September, pp. 1184-1190, ISBN 978-86-6075-028-2.
11. O.M. Pasca, C. Vigar, D.I. Stoia, *Short review on ankle-foot orthotics*, 11th International Conference "Research and Development in Mechanical Industry" – RaDMI 2011, Sokobanja, Serbia, 15 – 18 September, pp. 1199-1203, ISBN 978-86-6075-028-2.
12. M. Toth-Taşcău, D.I. Stoia, *Influence of the voluntary movements on the spine mobility evaluation*, Congress of International Society of Biomechanics ISB 2011, Brussels, 3-7 July, Proceedings of ISB 2011, pp. 1-2.
13. M. Toth-Taşcău, D.I. Stoia, *Influence of treadmill velocity on spatio-temporal parameters of human gait*, IEEE International Conference on E-Health and Bioengineering (EHB 2011), Iasi, 24-26 November 2011, pp. 155-158, ISSN 1726-9679.
14. D.I. Stoia, M. Toth-Taşcău, *Influence of treadmill velocity on joint angles of lower limbs during human gait*, IEEE International Conference on E-Health and Bioengineering (EHB 2011), Iasi, 24-26 November 2011, pp. 151-154, ISSN 1726-9679.
15. M. Toth-Taşcău, C. Saftescu-Jescu, D. Bugariu, O.M. Pasca, *Variation of posturographic parameters during lumbar spine movements*, IEEE International Conference on E-Health and Bioengineering (EHB 2011), Iasi, 24-26 November 2011, pp. 159-162, ISSN 1726-9679.
16. M. Toth-Taşcău, C. Vigar, L. Rusu, O.M. Pasca, *Plantar arch index determination for a subject having flat – foot*, XI-th Symposium – Acoustics and Vibration of Mechanical Structures AVMS-2011, Timisoara, 26 May 2011, pp. 164-170, ISSN 1843-0902.
17. M. Toth-Taşcău, L. Rusu, F. Bălănean, C. Toader-Pasti, *Modelling and analysis of some stabilization plates for radius fractures*, XI-th Symposium – Acoustics and Vibration of Mechanical Structures AVMS-2011, Timisoara, 26 May 2011, pp. 158-163, ISSN 1843-0902.
18. B. Almajan-Guta, C. Avram, A.M. Rusu, H. Filipescu, V. Almajan-Guta, O. Cluci, L. Pop, M. Oravitan, *Incentive techniques and airway clearance therapy in teenagers with cystic fibrosis*, 6th World Congress of ISPRM, San Juan, Puerto Rico, 12-16 June 2011, pp. 42-44, ISBN 978-88-7711-616-1.
19. M. Oravitan, C. Avram, A.M. Rusu, L.D. Hoble, B. Almajan-Guta, *Optimizing the somatic and cardio-metabolic parameters at young obese by modifying the lifestyle and implementing an individualized physical training protocol*, 6th World Congress of ISPRM, San Juan, Puerto Rico, 12-16 June 2011, pp.102-103, ISBN 978-88-7711-616-1.
20. C. Avram, M. Oravitan, B. Almajan-Guta, L. Hoble, A. Rusu, R. Dragoi, *Interval exercise training effectiveness in sleep apnea patients with metabolic syndrome*, 6th World Congress of ISPRM, San Juan, Puerto Rico, 12-16 June 2011, pp. 20-22, ISBN 978-88-7711-616-1.

#### PhD THESES

- Ovidiu Ghiba - *Contributions to conception and realization of hip prostheses*

#### PhD STUDENTS

- Delia Bugariu – *Research and contributions to the design and development of knee prostheses.*
- Cristian Săftescu-Jescu – *Studies of lumbar spine implants for reintegration, using modern methods and techniques.*
- Teodora Ioanovici – *Evaluation of thermo mechanical properties of biocompatible materials used in implantology.*
- Andrei Crăciun – *Telemedicine systems to support chronically ill people.*
- Cristian Toader-Pasti – *Research on optimizing the orthopedic implant systems.*
- Flavia Bălănean – *Studies and research on elbow joint implants.*
- Oana Maria Paşca – *Studies and research on ankle and foot orthoses.*
- Krepelka Mircea - *Prospective study on geometrical parameters of hip joint prostheses.*

#### PERSPECTIVES

The **Medical Engineering Research Centre** will continue to develop research in the field of Medical Engineering, especially in:

- *Fundamental and applied Biomechanics;*
- *3D Reconstruction of human body anatomical structures;*
- *Study of explanted implants in order to contribute to the development of new materials and devices with improved performances;*
- *Motion analysis of patients having different disorders in order to evaluate the disability or the rehabilitation process;*
- *Manufacturing of new implant models and prosthetic devices.*

In addition, the **Medical Engineering Research Centre** will enforce:

- *Promoting the Medical Engineering Specialization including master degree studies in Politehnica University of Timișoara.*
- *Development of PhD programs in the field of Medical Engineering, for engineers and other*

specialists in the medical area, tissue engineering, orthopedics, rehabilitation, etc.

- *Promoting the collaboration* in related fields with universities and research institutes.

#### RESEARCH CENTRE TEAM

##### PERMANENT MEMBERS

- Professor Ph.D. Eng. Mirela TOTH TASCAU
- Professor Ph.D. Eng. Mircea DREUCEAN
- Lecturer Ph.D. Eng. Cosmina VIGARU
- Lecturer Ph.D. Eng. Lucian RUSU
- Lecturer Ph.D. Eng. Antonius STANCIU
- Lecturer Ph.D. Tudor BINZAR
- Lecturer Ph.D. Guta Bogdan ALMAJAN
- Assistant Ph.D. Flavius Lucian PATER
- Assistant Ph.D. Eng. Dan Ioan STOIA
- Assistant Ph.D. Eng. Karoly MENYHARDT

##### TEMPORARY MEMBERS

- Pd.D. Student Oana PASCA
- Ph.D. Student Flavia BALANEAN
- Ph.D. Student Andrei Mihai CRACIUN

##### PH.D. STUDENTS WORKING IN RESEARCH CENTRE

- Pd.D. Student Ovidiu GHIBA
- Pd.D. Student Delia BUGARIU
- Pd.D. Student Cristian SĂFTESCU-JESCU
- Pd.D. Student Teodora IOANOVICI
- Pd.D. Student Cristian TOADER-PASTI
- Pd.D. Student Mircea KREPELKA

##### ADMINISTRATIVE STAFF

- Mariana CODAU
- Marinel COJOCARU

#### CONTACT

Prof.dr.eng. Mirela TOTH-TAȘCĂU – Director of *Medical Engineering Research Centre*

Faculty of Mechanical Engineering  
Bul. Mihai Viteazu, no. 1  
300222, Timișoara, Romania

E-mail: [mirela@cmpicsu.upt.ro](mailto:mirela@cmpicsu.upt.ro)  
<http://cmpicsu.upt.ro>

Tel/Fax: +40-256-403637

## NATIONAL CENTER FOR ENGINEERING OF SYSTEMS WITH COMPLEX FLUIDS – NCESCF

### GENERAL PRESENTATION

The *Hydraulic Machinery Division* within the Mechanical Engineering School of the Politehnica University of Timisoara, has been established in 1948, although courses on Hydraulics and Hydroelectric Power Plants have been taught since 1922. For the past half century, the Hydraulic Machinery Division has become an internationally recognized engineering school in turbomachinery hydrodynamics and cavitation, as well as in hydraulic and pneumatic power systems. Moreover, for the past three decades, a research group led by Acad.Prof.dr.doc.eng. Ioan Anton has developed new magnetic liquids and various technical applications.

The *National Center for Engineering of Systems with Complex Fluids (NCESCF)* is structured as a Multiple User Research Centre. Its research team joins professors and researchers from the “Politehnica” University of Timișoara, Hydraulic Machinery Division, and Romanian Academy – Timișoara Branch. NCESCF coordinates a nationwide research consortium including Politehnica University of Bucharest, Technical University of Civil Engineering From Bucharest, University “Dunarea de Jos” Galati, Technical University from Cluj-Napoca, University “Eftimie Murgu” Resita, and Technical University “Gh. Asachi” Iasi. At international level, NCESCF is actively engaged in academic and research agreements with Ecole Polytechnique Federale de Lausanne, Switzerland, University of Stuttgart, Germany, Luleå University of Technology, Sweden, Laval University, Canada, University of Porto, Portugal. The NCESCF also supports educational activities for master and PhD programs in mechanical engineering and computer science, as well as the Microsoft Academic Program within the “Politehnica” University of Timișoara.

### BRIEF HISTORY

- In 1997 was started the first pilot program financed by WORLD BANK (25000 USD) to set up the basic centre infrastructure;
- The main grant (317000USD) was finished in 2002, with the set up of the research infrastructure for the three main laboratories: magnetometry, rheology, and numerical simulation;

- A partnership with Microsoft Company allowed the continuous development and upgrade of the software infrastructure



In January 2006 we have started the evaluation procedure for NCESCF, resulting in the formal recognition as a national research center by the National University Research Council (CNCIS). The NCESCF joins now the staff from the Hydraulic Machinery Division and the research team from the Magnetic Liquids Laboratory, in a coordinated scientific research effort.

### MISSION

The *National Center for Engineering of Systems with Complex Fluids (NCESCF)* main goal is to support high level research and education in the domain of complex fluids characterization, production, and application developments. Our three decades experience in producing magnetic liquids and developing engineering applications, as well as in cavitating flow theoretical and applicative studies, allows us to coordinate and support research programs in magnetometry, rheology and magnetorheology of multiphase fluids, nano-fluids, various polymers, as well as on complex hydrodynamic problems in hydraulic machines, hydromechanic equipments, biomedical applications. Our experimental and computational capabilities are able to support top level PhD research programs, as well as international scientific cooperations.

### RESEARCH FIELDS

- Mathematical and numerical modelling of complex fluid hydrodynamics, including fluids with complex rheology, two-phase cavitating flows, turbulent 3D flows in complex geometries;

- Mathematical and numerical modelling of turbomachinery swirling flows as well as development and testing of novel flow control methodologies using magnetorheological devices;
- Development of research and professional software for parallel computing with applications in engineering hydrodynamics, turbomachineries, hydromechanical equipment;
- Analysis and optimization of hydraulic turbomachines, in order to improve both efficiency and cavitating behaviour;
- Flow properties of magnetic nanofluids and composites, magnetorheological fluids, polymeric melts, emulsions, gels;
- Magnetic and magnetorheological properties of magnetizable complex fluids;
- Specially tailored magnetic fluids as cooling agents: nucleate boiling heat transfer under the influence of a magnetic field;
- Magnetic and rheological characterization of bio-compatible/bioactive magnetizable fluids, ointments, composites for applications in plant biology and veterinary medicine;
- Magnetizable nanocomposite polymers with micrometric reinforcement elements;
- Engineering applications: rotating seals for high vacuum and moderate pressures, inductive sensors, MRF dampers;

#### KEYWORDS

Numerical hydrodynamics, cavitation, hydraulic turbines and pumps, hydraulic drives, parallel computing, complex fluids, magnetic nanofluids, magnetorheological fluids, magnetizable nanocomposites, magnetic properties, rheological properties.

#### ACTIVITIES

- *Numerical Simulation* in hydrodynamics of turbomachinery and hydraulic equipment and development of software bases for intelligent machines and installations
- *Development of numerical methods* to simulate the flow in turbomachines, cascades and development of complex models to determine the universal characteristics of cascades and turbomachines
- *Constructive solutions* for turbines and micro-turbines and research and design of turbomachines
- *Optimization of hydraulic machinery* using modern numerical methods
- *Cavitation* in turbomachinery with application to Francis and Kaplan turbines, cavitation erosion of materials used for hydraulic machines.

- *Design* of hydraulic drive systems for several industrial applications, modular optimization of the structures and elements of hydraulic drives systems
- *Experimental tests* on standard and proportional hydraulic equipment, using automated acquisition of experimental data
- *Complex characterization* of magnetic nanofluids and composites, magnetorheological fluids, polymeric melts, emulsions, gels: oscillatory and rotational rheometry, magnetometry;
- *Research and production* of new magnetic nano-fluids, magnetorheological fluids;
- *Application development* using magnetic fluids, in aerospace and bio-medical projects;
- *Numerical simulation* of flows with complex rheology and/or complex geometries, cavitating flows, applications for turbomachinery analysis and optimizations.
- *Software development* customized for special engineering applications;
- *Educational activities* in mechanical engineering and computer science, including master and PhD programs.

#### RESEARCH RESULTS

- Numerical analysis and stability analysis of decelerated swirling flows in hydraulic turbine draft tube; development of novel flow control techniques for Francis turbines operated at partial discharge.
- Full three-dimensional flow simulation and analysis in Kaplan and Francis hydraulic turbines;
- Parallel computing algorithms, development and implementation;
- Technical solutions for micro-hydro-turbines and development of design methods for hydraulic turbomachinery design;
- Static and dynamic identification and study of transients in pumps and turbines;
- Hydrodynamics of cavitation with applications to Kaplan and Francis turbines;
- Cavitation erosion studies for materials used in hydraulic turbines;
- Experimental investigations for hydraulic proportional equipment;
- Simulation and analytical modelling of flows in hydraulic poppet valves;
- Advanced characterization methods of the flow and magnetic behaviour of complex fluids and nanocomposites;
- High performance multifunctional materials for magnetically controlled heat transfer processes;
- Rotating seals, sensors, semiactive dampers;
- Biomedical applications.



*Vortex rope mitigation in the draft tube cone of a Francis turbine operating at partial discharge using the jet control technique.*

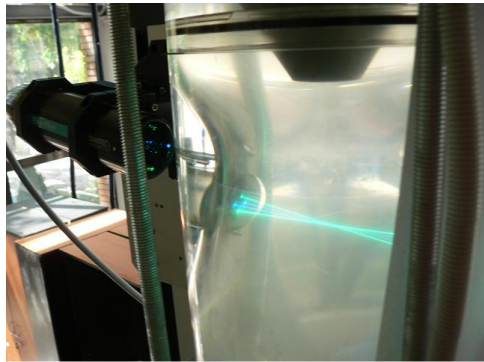
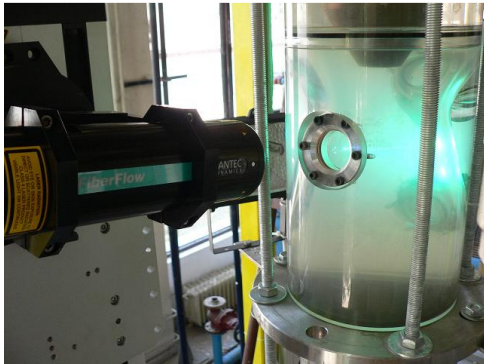

*Closed loop test rig for experimental investigations of swirling flows and laser system to measure the velocity profiles*

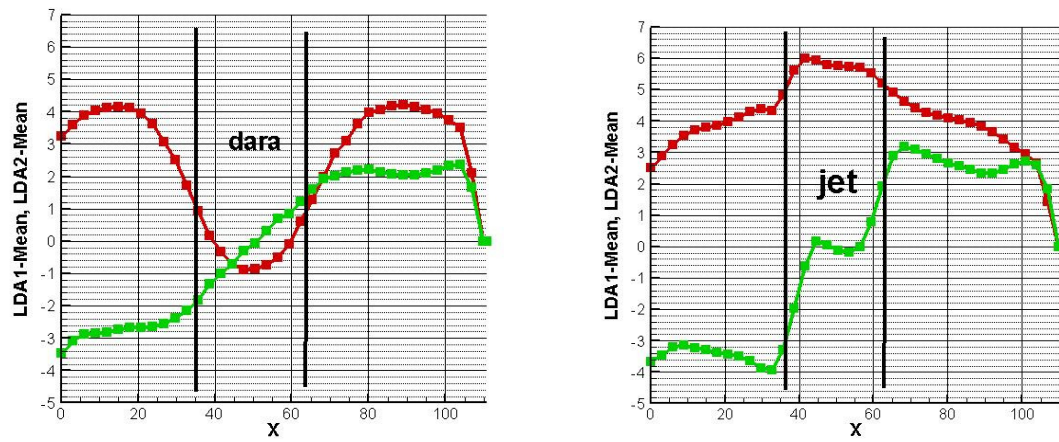

Velocity profiles without (left) and with (right) control jet.

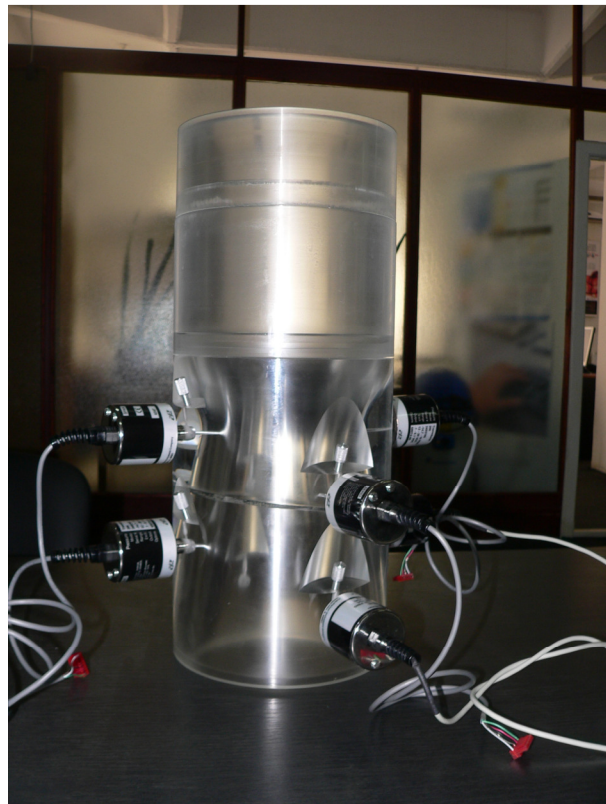
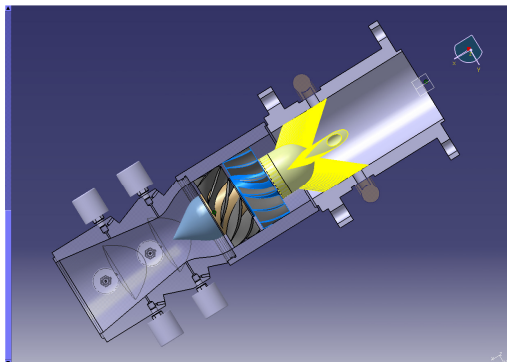
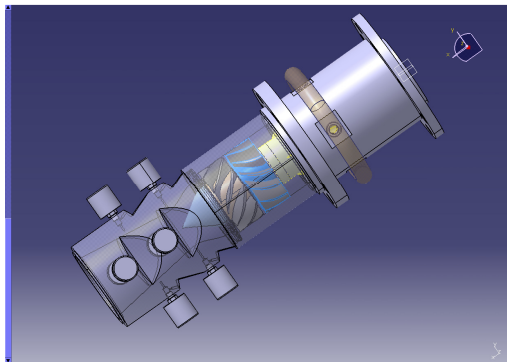

Test section for pressure measurements

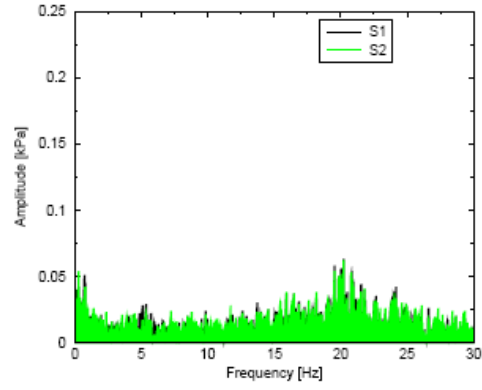
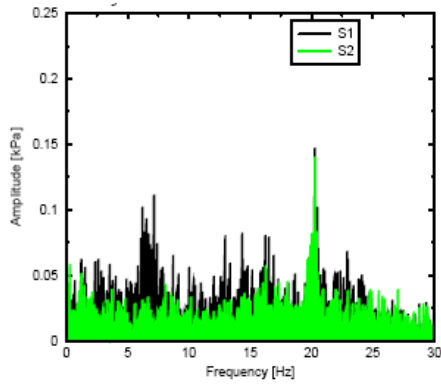

Fourier transform of pressure fluctuation without and with jet control

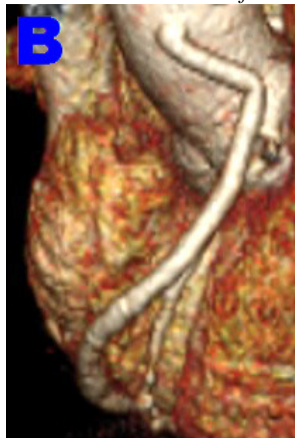

Venous bypass graft, 3D geometrical reconstruction.

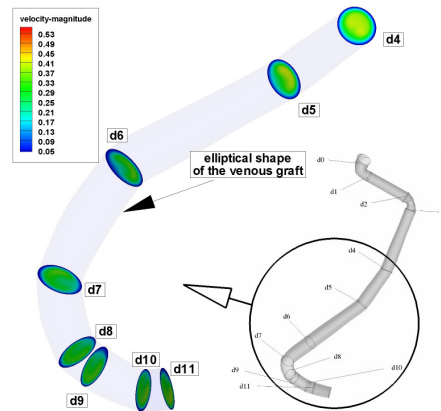

Velocity field computed in the venous bypass graft

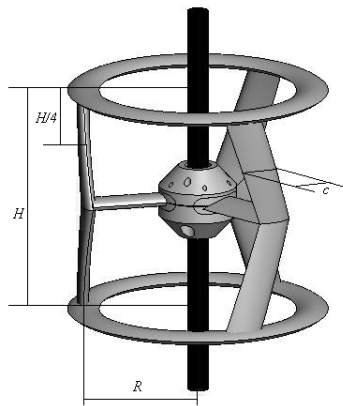

Achard turbine.

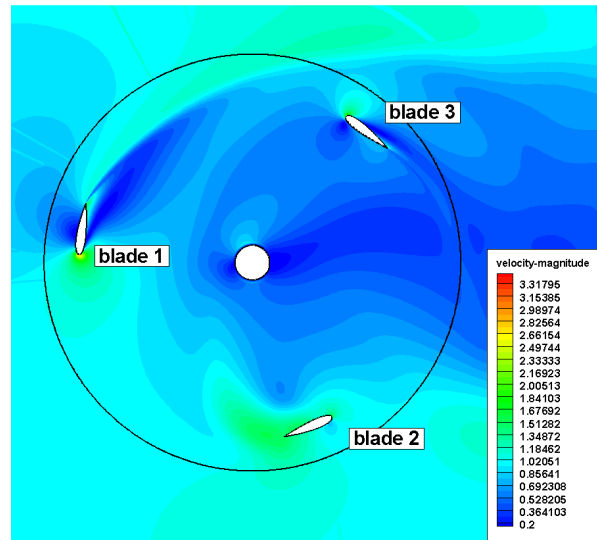
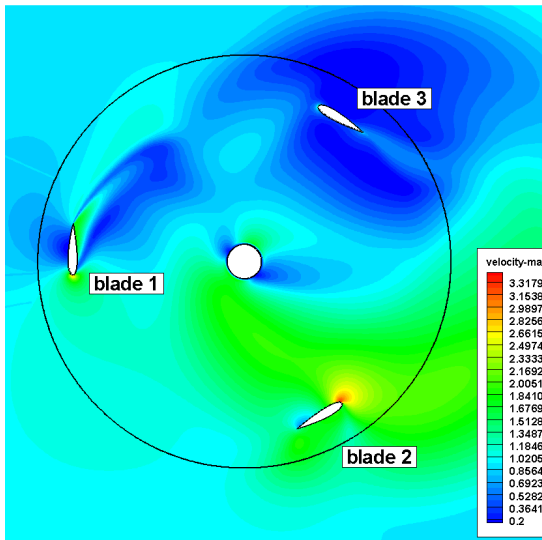

Velocity field magnitude for different value of the azimuthal angle of the blade

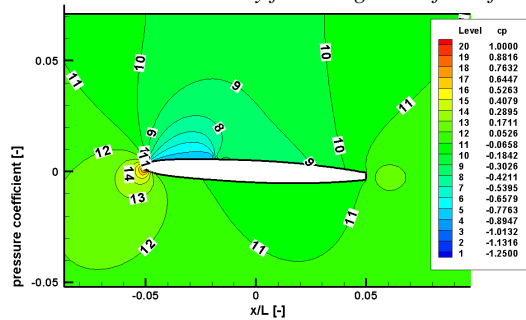

Pressure coefficient distribution on the NACA 0009 hydrofoil at 2,5 degree angle of attack and cavitation number 0.81

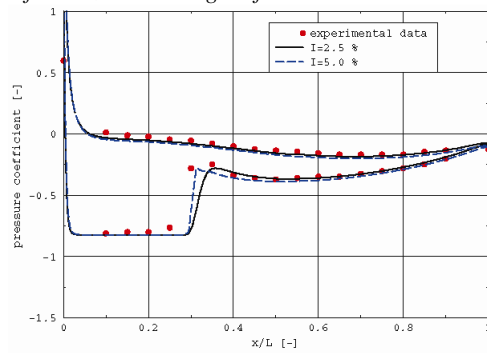

Pressure coefficient distribution of the different turbulence intensity for NACA 0009 hydrofoil at cavitation number =0.81.

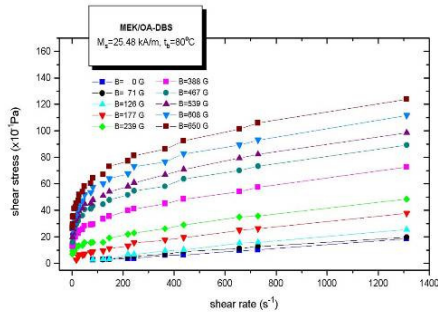

Magnetic field induced non-Newtonian flow behaviour of a strongly polar magnetic nanofluid

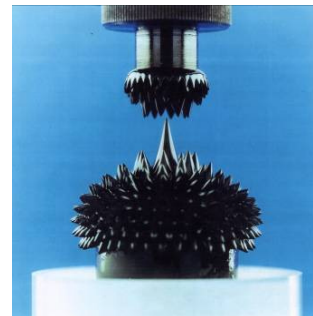

Surface instabilities



### Magnetometry Laboratory

- VSM 880 magnetometer
- the DMS Vibrating Sample Magnetometer (VSM) is a computer-controlled measurement system capable of characterizing a wide variety of magnetic samples
- The VSM supports all known magnetic measurements such as Hysteresis and Minor Loops, IRM and DCD Remanence Loops, SFD, Delta M and Henkel Plots, and Angular and AC Remanence Loops. Any series of measurements can be run without user intervention, using the flexible *EasyVSM* software.



### Rheology Laboratory

The PHYSICA MCR 300 rheometer performs a wide range of steady and dynamic tests in both CSS and CSR mode. It covers a wide range of applications, from generating simple flow curves to the dynamic analysis of complex fluids, melts, and co-polymers:

Shear stress (CSS), Creep and recovery, Normal force, Stress relaxation, Linear tensile and compression, Amplitude sweep, Frequency sweep, Temperature sweep, Time sweep, Multiwave, Oscillation with superimposed rotation or any combination of the above. Our rheometer has additional magnetorheological capabilities, as well as a wide range of temperature settings (up to 300 Celsius).

### Numerical Simulation and Parallel Computing Laboratory

Hardware infrastructure:

- 14 HP workstations computer cluster, PIV, 2,2 GHz, 1 GB RAM
- IBM X225 Windows server
- Dual PIII, 2GB RAM Linux server
- 5 workstations, DUAL INTEL XEON 3 GHz, 4 GB RAM.
- TYANPSC supercomputer with 10 processors on 64 bit and 40 GB RAM, data storage of 1.2 TB with fast acces.

Software infrastructure

- FLUENT/FIDAP/POLYFLOW suite for a wide range of numerical flow simulations; available for parallel computing
- TECPLOT for advanced data post-processing
- Software for developing parallel computing applications.

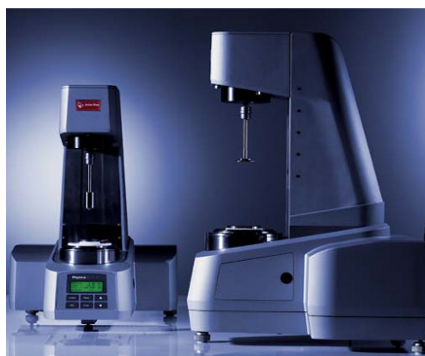

### RESEARCH CONTRACTS

1. Magnetic Fluid – New Insulated and Cooling Medium for Power Transformers – MAFINCO 7-018/2009 PN II - ERA-NET CNMP/ANCS Total ammount: 2011-156.000 lei Coord.: UP Timisoara-CNISFC; P1: Acad. Rom. - Fil. Timisoara; P2: SC ROSEAL SA Odorhei STOIAN Floriana Daniela, HOLOTESCU Sorin, HAN Adelina, DOBRA Andreea, CRAINIC Nicolae, MARINICA Oana, BALANEAN Florica, GIULA George.
2. Nanotechnology in Romania: prospective study 210/2010 PN-II Capacitati ANCS, Total ammount: 2011-150.000 lei Coord.: IMT Bucuresti; P1: INCDFM Bucuresti; P2: INCDFLPR Bucuresti; P3: ICM "Petru Poni" Iasi; P4: UT "Ghe. Asachi" Iasi; P5: UP Timisoara - CNISFC; P6: INCDFM ICPE-CA Bucuresti; P7: Univ. "Babes-Bolyai" Cluj Napoca - ICI Bio-Nano-Stiinte; P8: UPBucuresti Nicolae Calin Popa, Floriana D. Stoian, Vlad Socoliuc, Oana Marinica, George Giulia, Florica Balanean.

### PUBLICATIONS

#### ISI JOURNAL PAPERS

1. S. Holotescu, Floriana D. Stoian, Oana Marinica, L. Kubicar, P. Kopcansky, M. Timko, *Utilization of the magnetogranulometric analysis to estimate the thermal conductivity of magnetic fluids*, J. Magn. Mater. vol. 323 (10), pag. 1343 – 1347.
2. Petri C. Papaphilippou, A. Pourgouris, Oana Marinica, Alina Taculescu, G.I. Athanasopoulos, L. Vekas, Theodora Krasia-Christoforou, *Fabrication and characterization of superparamagnetic and thermoresponsive hydrogels based on oleic-acid-coated Fe(3)O(4) nanoparticles, hexa(ethylene glycol) methyl ether methacrylate and 2-(acetoacetoxy)ethyl methacrylate*, J. Magn. Mater. vol. 323 (5), pag. 557 – 563

### PERSPECTIVES

- Development of new nano-fluid materials and magneto-rheological suspensions, with aerospace and bio-medical applications;
- Development of new numerical simulation techniques for complex 3D cavitating flows.
- Development of new numerical simulation techniques for complex 3D biomedical applications.

### RESEARCH TEAM

- Prof.dr.eng. Romeo SUSAN-RESIGA, Director
- Dr.phys. Ladislau VEKAS, Scientific Director, head of the Rheology Laboratory
- Dr.eng. Sandor BERNAD, Executive Director
- Dr.eng. Sebastian MUNTEAN, head of the Numerical Simulation Laboratory
- Assoc.prof.dr.eng. Floriana STOIAN, head of the Magnetometry Laboratory
- Prof.dr.eng. Liviu ANTON
- Prof.dr.eng. Ilare BORDEAȘU
- Prof.dr.eng. Alexandru BAYĂ
- Prof.dr.eng. Mircea BĂRGLĂZAN

- Prof.dr.eng. Francisc GYULAI
- Prof.dr.eng. Mircea POPOVICIU
- Prof.dr.eng. Victor BĂLĂȘOIU
- Conf. dr.eng. Teodor MILOȘ
- Sl. dr.eng. Eugen DOBÂNDĂ
- Sl.dr.eng. Cornel VELESCU
- Sl.dr.eng. Ioan PĂDUREAN
- Sl.dr.eng. Adriana Sida MANEA
- Sl.dr.eng. Adrian BEJ
- Asist.dr.eng. Ionel BACIU
- Assist. dr.eng. Adrian STUPARU
- Asist.ing. Rodica BĂDĂRĂU
- Asist.dr.eng. Daniel Cătălin STROIȚĂ
- Fiz. Oana MARINICA, CS
- Phd. Stud. Alin BOSIOC
- Phd. Stud. Constantin TANASA
- Phd. Stud. Irina MOISA
- Phd. Stud. Alin JURCHELEA
- Phd. Stud. Adrian KARABENCIOV
- Phd.Stud. Nicolae BIRAU
- Phd.Stud. Elena DIMIAN
- Phd.Stud. Gheorghita GANGA
- Phd.Stud. Tiberiu CIOCAN
- Stud. Mariana TODIRUȚĂ
- Stud. Master ing. Laurențiu MIRCEA
- Stud. Master ing. Laurențiu Daniel CĂLIN
- Stud. Dușita PAVLOV
- Stud. Laura SĂLCIANU
- George GIULA
- Tehn. Ioan POTORAC

### CONTACTS

Prof.dr.eng. Romeo SUSAN-RESIGA,  
 Director NCESCF  
 Tel/Fax: +40-256-403692  
 E-mail: [resiiga@mh.mec.upt.ro](mailto:resiiga@mh.mec.upt.ro);  
[romeo.resiga@mec.upt.ro](mailto:romeo.resiga@mec.upt.ro)  
<http://mh.mec.upt.ro/cnisfc>

Prof.dr.eng. Ilare BORDEASU  
 Chair of the Hydraulic Machinery Div.  
 Tel: +40-256-403680  
 E-mail: [ilarica@mec.upt.ro](mailto:ilarica@mec.upt.ro)  
<http://www.mec.upt.ro/~mh/>

## RESEARCH CENTRE FOR VIBROIMPACTS AND MECHANICAL VIBRATIONS

### GENERAL PRESENTATION

Because of the existing tradition and outstanding achievements in the scientific research, the premises appeared for funding a centre of scientific excellence focused on the field of vibroimpacts, mechanical vibrations and technical acoustics. As a consequence of the competitions organized by CNC SIS, concerning the identification and evaluation of research centers, the results obtained in these fields were specially appreciated, so the research centre was recognized as a type B research centre. Consequently, CNC SIS issued the certificate no. 15/CC-B from 11/05/2001, recognizing the **research centre VIBROIMPACTS AND MECHANICAL VIBRATIONS**. It has to be emphasized that the research in the field of the vibroimpacts is done, with priority, by the staff of this centre. As of 2009, the Laboratory of Acoustics and Vibration within this centre was accredited by RENAR (Romanian accreditation body for testing laboratories), in accordance with the standard SR EN ISO/CEI 17025, which means that test reports issued by this laboratory are accepted across Europe. The National Accreditation Body's mark on these reports guarantees their recognition, equivalence and reliability across Europe.

The members of this centre were involved in many national and international projects concerned with both theoretical and experimental problems related to vibration, vibro-impacts and acoustics.

### MISSION

The main mission of the centre is to realize specific activities of continuous training, advanced research, technical assistance, documentation and technical expertise. In order to realize its mission, the centre has as objectives:

- promotion of works of fundamental and applied research in the field of vibroimpacts, vibrations, nonlinear dynamics and technical acoustics;
- expertise and consulting for the industrial environment;
- promotion of the research fields and realization of cooperation programs with other research institutes in these fields;

### RESEARCH FIELDS

The main fields of the research are:

- vibroimpacting interactions and vibroimpacts

- mechanical vibrations, linear and nonlinear vibrations
- environmental acoustics, technical acoustics
- nonlinear dynamics in mechanical engineering
- vibration of nonlinear systems

### KEYWORDS

Vibration, vibroimpact, noise, impact, spectrum, prediction, diagnosis, analytical solutions, homotopy methods, variational methods, iterative methods, stability, weakly and strongly nonlinearity

### ACTIVITIES

The research activity of this centre spans the full spectrum of activities, from fundamental studies aimed at developing new analysis methods to experimental studies:

- Methods for the study of the vibrations of mechanical systems, with applications in engineering.
- Theoretical and experimental studies, concerning development of new methods and devices for decreasing the levels of vibrations and noise;
- Dynamics of vibroimpact systems. Theoretical and experimental methods for the study of stable vibroimpact motions;
- Modeling of working regimes of vibroimpact mechanisms, calculus and optimization algorithms;
- Fault diagnosis by vibrations at machines and equipment;
- Assessment of isolation capacity at air noise of building elements. Determination of noise levels at civil buildings;
- Assessment of noise levels in industrial and urban environment
- Evaluation of human exposure to hand-arm and whole-body vibration
- Test reports on acoustic and vibration real problems
- Application of homotopy methods and variational methods to the study of nonlinear phenomena
- Development of analytical approximate techniques for non-linear and strongly non-linear problems

## PUBLICATIONS

### PAPERS IN ISI JOURNALS

1. L. Bereteu, G.E. Drăgănescu, D. Stănescu, C. Sinescu, Quantitative measurement of speech sound distortion with the aid of minimum variance spectral estimation method for dentistry use, *Computer Methods in Biomechanics and Biomedical Engineering*, 14 (2011) 1097-1104
2. V. Marinca, N. Herișanu, Nonlinear dynamic analysis of an electrical machine rotor-bearing system by Optimal Homotopy Perturbation Method, *Computers and Mathematics with Applications*, 61 (2011) 2019–2024
3. V. Marinca, N. Herișanu, An optimal iteration method with application to the Thomas-Fermi equation, *Central European Journal of Physics*, 9 (2011) 891-895
4. V. Marinca, N. Herișanu, Explicit and exact solutions to cubic Duffing and double-well Duffing equation, *Mathematical and Computer Modelling*, 53 (2011) 604–609
5. V. Marinca, N. Herișanu, An optimal homotopy asymptotic approach applied to nonlinear MHD Jeffery-Hamel flow, *Mathematical Problems in Engineering*, Art.no. 169056, 2011

### PAPERS IN OTHER JOURNALS

1. D.V. Stănescu, L. Bereteu, G.E. Drăgănescu, , Identification of a modified Van der Pol vibrating system, *Scientific Bulletin of the „POLITEHNICA” University of Timisoara, Transactions on Mechanics*, Vol. 56 no.2, 2011, pp 1-4

### INTERNATIONAL CONFERENCES

1. V. Marinca, N. Herișanu, Oscillations of a cantilever beam with end mass and vertical base excitation, *Proceedings of the XI-th Symposium AVMS'2011*, pp.69-76
2. N. Herișanu, V. Marinca, Solution of some rotating electric machine vibration using Optimal Homotopy Perturbation Method, *Proceedings of the XI-th Symposium AVMS'2011*, pp.77-84

3. D. Simoiu, L. Bereteu Simulations of air flow over a parabolic antenna, *Proceedings of the XI-th Symposium AVMS'2011*, pp.95-100

### BOOKS

1. V. Marinca, N. Herișanu, *Nonlinear Dynamical Systems in Engineering. Some Approximate Approaches*, Springer Verlag, Berlin, ISBN 978-3-642-22735-6, 395 pages, 2011
2. V. Marinca, N. Herișanu *Mechanics. Dynamics*, “Politehnica” Publishing House, ISBN 978-606-554-374-4, 396 pages, 2011

## PERSPECTIVES

Taking into account the research facilities, systems and equipments as well as the human resources of the centre, it is expected in the near future to significantly increase its presence in the scientific landscape at national and international level in the field of vibrations, vibroimpacts and technical acoustics. The results obtained by the centre's staff will be further developed in both fundamental and application directions. The research center will also promote continuous research activities in national and international research projects as well as in some research projects requested by the industry.

## RESEARCH TEAM

- Prof. dr. ing. Liviu BERETEU
- Prof. dr. Vasile MARINCA
- Prof.dr. Gheorghe DRĂGĂNESCU
- Assoc. prof. dr. ing. Nicolae HERIȘANU
- Lect. dr. Valeriu ANGHELESCU
- Lect. dr. ing. Gheorghe LUCA
- Asist. dr. ing. Ramona NAGY
- Eng. Dan STANESCU, Ph.D Student
- Eng. A. Perescu, PhD Student

## CONTACT

Prof. dr. ing. Liviu BERETEU  
 Department of Mechanics and Vibrations  
 Faculty of Mechanical Engineering  
 Bul. Mihai Viteazu, no. 1  
 300222, Timișoara  
 E-mail: liviu.bereteu@mec.upt.ro  
 Tel.: +40-256-403522

# INTEGRATED ENGINEERING RESEARCH CENTRE

## I. E. R. C.

### GENERAL PRESENTATION AND MISSION

The *Integrated Engineering Research Centre (IERC)* is organized within the Department of Materials & Manufacturing Engineering (IMF) as a research unit and transfer of technology of the “Politehnica” University of Timisoara. IERC is accredited by the National Scientific Research Council for Higher Education (CNCSIS - Romania) with the certificate CNCSIS no. 103 / CC-C in May 11, 2001 and by “Politehnica” University of Timisoara, in July, 21, 2011.

The mission of IERC is to coordinate teams of researchers from the Department of Materials & Manufacturing Engineering (IMF), who are developing programs in the integrated engineering field of research.

### RESEARCH FIELDS

The main fields of research are:

- Products, processes and manufacturing systems;
- Integrated product design;
- Collaborative distributed design;
- Conceptual design;
- Product lifecycle management;
- Integrated control of the manufacturing processes and systems;
- Equipments and technologies for non-conventional processes;
- Computer aided design and manufacturing of plastic parts;
- Computer aided design and manufacturing of injection moulds for plastic materials;
- Ultrasonic activation of plastic and composite materials processing;
- Rapid prototyping and reverse engineering of the corresponding moulds;
- Flexible cells for plastics manufacturing;
- Quality systems and maintenance in plastics manufacturing.

### KEYWORDS

Integrated design; Collaborative distributed design; Manufacturing engineering; Product lifecycle management; Non-traditional machining processes, equipment and technologies; Quality assurance; Rapid prototyping; Three-dimensional measurements; Reverse engineering; Cold forming; Plastics technologies.

### ACTIVITIES

- IERC assure the co-ordination and harmonization of the training programs through scientifically research (PhD. programs, post-graduated programs) for the researchers or research teams. The master program developed by IERC is named “Integrated Engineering”. The graduate and PhD. programs coordinated by IERC are in the field of Industrial Engineering.
- The research teams from IERC develop: fundamental and applicative research activities; products and technology design activities; technological development and technology transfer all attending the present industrial demands.
- IERC is involved in national and international research programs and organizes the International Conference on Integrated Engineering.
- IERC members are part of the following professional bodies and associations:
  - EMIRAcle – European Manufacturing and Innovation Research Association, a cluster leading experience;
  - ETRIA – The European TRIZ Association;
  - ECQA – The European Certification & Qualification Association;
  - AGIR – The General Association of the Engineers, Romania
  - AUIF – The Academic Association of Manufacturing Engineering, Romania
  - ARTN – The Romanian Association of Nonconventional Technologies
  - MODTECH – The Professional Association in Modern Manufacturing Technologies, Romania

### RESEARCH CONTRACTS

1. Contract MNT 7-021/2010, *Ultrasonic assisted processes for machining of high precision components*, ERA-NET, Financer UEFISCDI, Director C. Turc, Value for UPT in 2011: 20500 Euro.
2. Contract 121/06.12.2011, *Studies to improve dimensional precision and the shape of the products in automotive industry*, Financer SC Continental Automotive Romania SRL, Director A. Tulcan, Value 6324 Lei;
3. Contract 130/16.12.2011, *Studies to improve dimensional precision and the shape of the products in automotive industry*, Financer SC Continental Automotive Romania SRL, Director A. Tulcan, Value 2678,4 Lei;

- Contract 81/04.07.2011, *Technical assistance for statistic control and 3D measurements*, Financer SC Continental Automotive Romania SRL, Director A. Tulcan, Value 5720 Lei

### PUBLICATIONS

#### BOOKS

- Drăghici G., Drăghici A., Multisite PLM Platform: A Collaborative Design Environment, in *Enterprise Information Systems Design, Implementation and Management: Organizational Applications*, Maria Manuela Cruz-Cunha and Joao Varajao (Eds.), Business Science Reference (an imprint of IGI Global), Hershey New York, HD30.213.E583, Copyright © 2011 by IGI Global, DOI: 10.4018/978-1-61692-020-3.ch029 ISBN13: 978-1-61692-020-3, ISBN10: 1-61692-020-3, EISBN13: 978-1-61692-021-0, pp.456-475
- Drăghici A., Izvercianu M., Drăghici G., Virtual Center for Entrepreneurship Development, in *Enterprise Information Systems Design, Implementation and Management: Organizational Applications*, Maria Manuela Cruz-Cunha and Joao Varajao (Eds.), Business Science Reference (an imprint of IGI Global), Hershey • New York, HD30.213.E583, Copyright © 2011 by IGI Global, DOI: 10.4018/978-1-61692-020-3.ch030 ISBN13: 978-1-61692-020-3, ISBN10: 1-61692-020-3, EISBN13: 978-1-61692-021-0, pp.476-495
- Felicia Banciu, *Developing of a Innovative, Collaborative Product Design Platform*, PhD. Thesis, Ed. POLITEHNICA, Timisoara, 2011, ISBN 978-973-625-612-7
- Ana-Andreea Mihărtescu, *Customer Requests Integration in the Product Design Stage*, PhD. Thesis, Ed. POLITEHNICA, Timisoara, 2011, ISBN 978-973-625-612-7
- Ioan Daniel Rotar - *Studies of the polymeric materials flow processes through the interstices of the forming devices*, PhD. Thesis, Ed. POLITEHNICA, Timisoara, 2011, ISBN 978-973-625-612-7
- Vlad Adrian Țuț - *Research regarding the expert system for injection moulds conception*, PhD. Thesis, Ed. POLITEHNICA, Timisoara, 2011, ISBN 978-973-625-612-7
- Adrian Oriță, George Drăghici & Pierre Repetti, Methodology of Definition of Delivery Requirements, Proceedings of the International Conference - Modern Technologies, Quality and Innovation, ModTech 2011, 25-27 May, Vadul lui Voda-Chisinau, Moldova, ISSN 2069-6736, p.793-796
- Adrian Oriță, George Drăghici, J.-L. Beney & Pierre Repetti, Using TRIZ to find Alternatives Solutions, Proceedings of the International Conference - Modern Technologies, Quality and Innovation, ModTech 2011, 25-27 May, Vadul lui Voda-Chisinau, Moldova, ISSN 2069-6736, p.789-792
- Eugen Pămîntaş, Felicia Banciu, Tool's Profile Adjustment for High Speed Form Turning, Proceedings of the International Conference - Modern Technologies, Quality and Innovation, ModTech 2011, 25-27 May, Vadul lui Voda-Chisinau, Moldova, Vol.II, p. 809, ISSN 2069-6736;
- Felicia Banciu, George Drăghici, Eugen Pămîntaş, Cristian Turc, Product Functions in Systematic Design and Axiomatic Design Approaches, Proceedings of the International Conference - Modern Technologies, Quality and Innovation, ModTech 2011, 25-27 May, Vadul lui Voda-Chisinau, Moldova, Vol.II, p. 805, ISSN 2069-6736;
- George Belgiu, Felicia Banciu, Eugen Pămîntaş, C. Cărașu, C. Turc, Flexible Manufacturing System Management – Issues Concerning the Modeling, Simulation and Optimization, Proceedings of the International Conference - Modern Technologies, Quality and Innovation, ModTech 2011, 25-27 May, Vadul lui Voda-Chisinau, Moldova, Vol.I, pp. 57, 7p. ISSN 2069-6736;
- Eugen Pămîntaş, C. Turc, G. Belgiu, F. Banciu, Cutting Tool Failure – Inadequate Design Methodology or Process Insufficient Known, Proceedings of the International Conference - Modern Technologies, Quality and Innovation, ModTech 2011, 25-27 May, Vadul lui Voda-Chisinau, Moldova, Vol.I, pp. 77, 4p. ISSN 2069-6736;
- Felicia Banciu, George Drăghici, George Belgiu, A New Functional Analysis Approach, Annals of the Oradea University, Fascicle of Management and Technological Engineering, CD-ROM Edition, Vol. X (XX), ISSN 1583 – 0691, pp. 5.9-14;
- Anca Drăghici, George Drăghici, Research related Knowledge Management Development in Romanian Engineering Education, Annals of the Oradea University, Fascicle of Management and Technological Engineering, CD-ROM Edition, vol. X (XX), nr.1, ISSN 1583-0691, pp. 5.98-5.105

#### PUBLISHED PAPERS

- Cristian-Gheorghe Turc, Dorian Ștef, George Belgiu, Daniel Rotar, An application of fuzzy logic methodology for working choosing, Proceedings of the International Conference - Modern Technologies, Quality and Innovation, ModTech 2011, 25-27 May, Vadul lui Voda-Chisinau, Moldova, ISSN 2069-6736, p. 1109;

10. Draghici A., Prostean G. I., Mocan M. L., Draghici G., State of Business Process Management in Companies from Romania West Region, Proceedings of the 7th International Conference on the Management of Technological Changes, 1-3 September 2011, Alexandroupolis, vol.2, Democritus University of Thrace, Greece, ISBN: 978-960-99486-3-0, pp. 501-504
11. Draghici A., Mocan M., and Draghici G., On-Line Training and Certification Solution for Business Process Managers, in M.M. Cruz-Cunha et al. (Eds.): CENTERIS 2011, Part I, CCIS 219, ISSN: 1865-0929, pp. 380-389, © Springer-Verlag Berlin Heidelberg 2011
12. Banciu F., Draghici G., Holistic Model for Innovative Product Design, Proceedings of the 2011 International Conference on Instrumentation, Measurement, Circuits and Systems, ICIMCS 2011, Volume 3, December 12-13, 2011, Hong Kong, ASME Press, ISBN: 978-0-7918-5990-2, pp.117-120
13. Draghici A., Dragoi G., Rosu S.M., Cotet C.E., Draghici G., Knowledge Applications Solutions at the SME Level in the e-Enterprise Business Intelligence, Proceedings of the 2011 International Conference on Instrumentation, Measurement, Circuits and Systems, ICIMCS 2011, Volume 3, December 12-13, 2011, Hong Kong, ASME Press, ISBN: 978-0-7918-5990-2, pp.121-124
14. Ștef D., Florică S., Drăghici G., Platform for Integrated Product Design and Manufacturing, Proceedings the 5<sup>th</sup> International Conference on Manufacturing Science and Education - MSE 2011, Vol. I, Sibiu, June 2-5, 2011, Romania, ISSN 1843-2522, pp.153-156
15. Draghici A., Foldvary-Schramko H-K., Draghici G., Researches for Knowledge Management Characterization in Engineering Education, Proceedings the 5<sup>th</sup> International Conference on Manufacturing Science and Education - MSE 2011, Vol. II, Sibiu, June 2-5, 2011, Romania, ISSN 1843-2522, pp.139-143
16. Draghici A., Draghici G., Riel A., Tichkiewitch S., Reseach Entrepreneurship Developement – A Possible Solution at the European Level, Proceedings the 5<sup>th</sup> International Conference on Manufacturing Science and Education - MSE 2011, Vol. II, Sibiu, June 2-5, 2011, Romania, ISSN 1843-2522, pp.135-138
17. Eugen Pămîntaş, Breaking Tool - Search the Possible Causes of Unwanted Crush, Proceedings of the 5th International Conference on Manufacturing Science and Education-MSE 2011, 02-05 June, Sibiu, Romania, Vol.I, p. 333, ISSN 1843-2522;
18. Eugen Pămîntaş, Chip Breakage on High-Speed Semi-Orthogonal Turning, Proceedings of the 5th International Conference on Manufacturing Science and Education-MSE 2011, 02-05 June, Sibiu, Romania, Vol.I, p. 337, ISSN 1843-2522;
19. Felicia Banciu, George Drăghici, Eugen Pămîntaş, Ion Grozav, Identify Functions, Failure Modes, Causes and Effects Using the TRIZ Functional Modeling, Proceedings of the 5th International Conference on Manufacturing Science and Education-MSE 2011, 02-05 June, Sibiu, Romania, Vol.I, p. 265, ISSN 1843-2522;
20. Cosma Cristian, Rotar Daniel, Cioana Cristian, Șerban Iancu, Redesigning Plastic Product, Materiale Plastice, vol. 48 (2011), p. 259, ISSN 0025-5289;
21. Mihaela Ciopec, Corneliu Mircea Davidescu, Adina Negrea, Ion Grozav, Lavinia Lupa, Cornelia Muntean, Petru Negrea, Adriana Popa, Studies regarding chromium ions adsorbition on DEHPA impregnated XAD7 using design of experiments for optimizing the chemical process, J. of Environmental Management, vol. 11 (2012), ISSN:1582-9596, F. 1,435;
22. Cioană Cristian, Tulcan Aurel, Dume Adrian, Șerban Iancu, Flow simulation on a Reverse Engineered part, Proceedings of the International Conference - Modern Technologies, Quality and Innovation, ModTech 2011, 25-27 May, Vadul lui Voda-Chisinau, Moldova, p. 217, ISSN 2069-6736;
23. Aurel Tulcan, Cristian Cioană, Cristian Cosma, Ion Grozav, Coordinate measuring machine measurement uncertainty study, Proceedings of the International Conference - Modern Technologies, Quality and Innovation, ModTech 2011, 25-27 May, Vadul lui Voda-Chisinau, Moldova, p.1105, ISSN 2069-6736;
24. Vlad Tuș, Cristian Cosma, Daniel Stan, Cristian Cioana, An expert system for making mold cavities, Proceedings of the International Conference - Modern Technologies, Quality and Innovation, ModTech 2011, 25-27 May, Vadul lui Voda-Chisinau, Moldova, p.1113, ISSN 2069-6736;
25. Cristian Cioană, Aurel Tulcan, Ion Grozav, Cristian Cosma, Scanning strategies for Aluminium and plastic parts, 4th International Conference on Advanced Materials and Structures - AMS'11, 26-28 Oct. 2011, Timisoara, Romania, Vol.1, p.31, ISBN: 978-606-554-374-4;
26. Iancu Șerban, Daniel Stan, Tudor Iclânzan, Alin Șirbu, Ultrasonic Activation of Microinjection Molding, Proceedings of the International Conference - Modern Technologies, Quality and Innovation, ModTech 2011, 25-27 May, Vadul lui Voda-Chisinau, Moldova, p.989, ISSN 2069-6736;
27. Iancu Șerban, Daniel Stan, Daniel Rotar, Vlad Tut, Techniques to Obtain Different Molding Runners Dies Used in Micro-Injection Molding, Proceedings of the International Conference -

- Modern Technologies, Quality and Innovation, ModTech 2011, 25-27 May, Vadul lui Voda-Chisinau, Moldova, p.993, ISSN 2069-6736;
28. Cristian Cioana, Aurel Tulcan, Cristian Cosma, Tudor Iclanzan, Reverse engineering for quality control, Proceedings of the International Conference - Modern Technologies, Quality and Innovation, ModTech 2011, 25-27 May, Vadul lui Voda-Chisinau, Moldova, Vol.1, p. 221, ISSN 2069-6736;
  29. Nicolae Sirbu, Viorel Serban, Daniel Stan, O. Oanca, Ultrasonic device for processing polymer composite materials, Proceedings of the International Conference - Modern Technologies, Quality and Innovation, ModTech 2011, 25-27 May, Vadul lui Voda-Chisinau, Moldova, p.1009, ISSN 2069-6736;
  30. Liliana Tulcan, Aurel Tulcan, Particular phenomena into the work space of the ultrasonic aided abrasive lapping, Nonconventional Technologies Review, nr.4/2011, pp. 59-62, Editura Politehnica, Timisoara, Vol.4, p.59, ISSN 1454-3087;
  31. Cristian Cosma, Cristian Cioana, Daniel Stan, Improvement of the quality for plastic parts. Reverse engineering applications, Scientific Bulletin Of The „Politehnica” University of Timișoara, Vol. 56(70), p. 55, ISSN 1224-6077;
  32. Daniel Stan, Iancu Serban, Aurel Tulcan, Nicusor Sirbu, Experimental device and influence parameters in ultrasonic activated extrusion of LDPE, Scientific Bulletin Of The „Politehnica” University of Timișoara, Vol. 56(70), p.17, ISSN 1224-6077;
3. Florică Stelian Cornel, *Collaborative product design in PDM/PLM platform*, Thesis supervisor: Prof. George Drăghici
  4. Ferician Florin Cornel, *Researches on the technological possibilities of using the plasma electronic guns*, Thesis supervisor: Prof. Tudor Iclănzan
  5. Serban Iancu, *Study of microinjection and injection of thin wall products*, Thesis supervisor: Prof. Tudor Iclănzan
  6. Cioana Cristian, *Improvement of the reverse engineering techniques by virtual re-modeling of the plastic parts*, Thesis supervisor: Prof. Tudor Iclănzan
  7. Adam Andrei, *Study of the quality in plastic parts manufacturing processes*, Thesis supervisor: Prof. Tudor Iclănzan

### RESEARCH TEAM

The human resources consist of researchers which are doctor degree graduates or which leads post-graduates programs. Also, in the team are working post-graduates and master students. The IERC management is assured by the director and the Scientific Council, which is composed of professors or associate professors that have been recognized for their research activity and results.

The members of the research team are:

- a) Permanent members:
  1. Prof. George Drăghici, IERC director
  2. Prof. Tudor Iclănzan
  3. Assoc. Prof. Ion Grozav
  4. Assoc. Prof. Eugen Pămîntaş
  5. Assoc. Prof. Crisanta-Alina Mazilescu
  6. Assoc. Prof. Daniel Stan
  7. Assoc. Prof. Aurel Tulcan
  8. Dr. Adrian But
  9. Dr. Cristian-Gheorghe Turc
  10. Dr. Cristian Cosma
  11. Dr. Adrian Dume
  12. Dr. Felicia Banciu
- b) Temporary members (PhD students):
  1. Iancu Serban
  2. Cristian Cioana
  3. Ioan Dorian Stef
  4. Stelian Cornel Florică

### CONTACT

Prof. George DRĂGHICI – IERC Director  
 Faculty of Mechanical Engineering  
 Bul. Mihai Viteazu, nr. 1  
 300223, Timișoara, Romania  
 Tel/fax: +40-256-403610  
 Fax: +40-256-403523  
 Web: <http://www.eng.upt.ro/ccii/>  
 E-mail: [gdraghici@eng.upt.ro](mailto:gdraghici@eng.upt.ro)

### PhD THESIS

1. Banciu Felicia, *Developing of a Innovative, Collaborative Product Design Platform*, Thesis supervisor: Prof. George Drăghici
2. Mihărtescu Ana-Andreea, *Customer Requests Integration in the Product Design Stage*, Thesis supervisor: Prof. George Drăghici
3. Tut Vlad, *Researches on expert systems in designing injection molds*, Thesis supervisor: Prof. Tudor Iclănzan
4. Rotar Daniel, *Study of plastic material flow in hot runners and cavities, with applications in microinjection*, Thesis supervisor: Prof. Tudor Iclănzan

### PhD THESIS in progress

1. Oriță Adrian, *Integrated product design methodology in PLM context*, Thesis supervisor: Prof. George Drăghici
2. Stef Ioan Dorian, *Integrated product development in Digital Factory context*, Thesis supervisor: Prof. George Drăghici





Collaborative Engineering lab



Manufacturing lab



Plastic materials injection lab



Reverse engineering lab



Three dimensional measurement lab



Ultrasonic lab



CNC simulation lab



CAD/CAM lab

## RESEARCH CENTRE FOR PROCESSING AND CHARACTERISATION OF ADVANCED MATERIALS

### MAIN RESEARCH FIELDS

Examinations and thermal analysis, design and elaboration of advanced materials and improvement of the processing technologies, thermo-mechanical processes for improving materials characteristics, training and consulting for specialists from the industry in the field of investigations, technology and designing of materials.

- Studies and investigations on metallic glasses Fe-Ni-P and Fe-Cr-P

**Keywords:** amorphous alloy, liquid quenching, ribbons, powders, thermo-stability, magnetic properties

- Studies and researches on behaviour of materials during welding and weldability of materials

**Keywords:** weldability, welding, microstructural investigations, mathematical modelling

- Manufacturing and characterization of advanced materials

**Keywords:** amorphous, metallic matrix composites, stainless steels, micro-alloyed steels

- Increasing fiability of machine parts by mean of surface treatments and use of advanced materials

**Keywords:** plasma nitriding, gas carbonising, surface inductive treatment

- Modern investigation of materials structure and properties, image acquisition and processing in optic and electronic microscopy

**Keywords:** digital photo camera, computer aided image processing, image archive

### STUDIES AND INVESTIGATIONS ON THE METALLIC GLASSES Fe-Ni-P AND Fe-Cr-P

#### FIELD DESCRIPTION

Metallic glasses are a new class of materials used in applications that require high saturation magnetic induction and low magnetic loss, in high strength fibres and for magnetic shielding.

#### ACTIVITIES AND RESULTS

Researches on Fe-Ni-P and Fe-Cr-P amorphous alloys allowed designing of an elaboration technology and corresponding facilities for amorphous ribbons and powders. The properties of the obtained ribbons and powders

were studied by X-ray analysis, in order to observe the materials amorphous change. The researchers aim is to obtain magnetic materials with outstanding properties.

### SHAPE MEMORY ALLOYS

#### FIELD DESCRIPTION

The shape memory alloys are materials with a large number of interesting properties as: shape memory effect, pseudoelastic behaviour and high dumping capacity.

#### ACTIVITIES AND RESULTS

Researches on Fe-Ni-P and Fe-Cr-P amorphous alloys allowed designing of an elaboration technology and corresponding facilities for amorphous ribbons and powders.

The properties of the obtained ribbons and powders were studied by X-ray analysis, in order to observe the materials amorphous change. The researchers aim is to obtain magnetic materials with outstanding properties.

### METAL MATRIX COMPOSITES

#### FIELD DESCRIPTION

Particle reinforced metal matrix composites are relatively new class of materials which combine high mechanical properties with cost that are significant lower in comparison with long fiber reinforced composites.

#### ACTIVITIES AND RESULTS

A new class of particle reinforced composites based on a hardenable Al-Cu-Si-Mg reinforced with SiC particles (10  $\mu\text{m}$  average dimension) has been produced via a powder metallurgy technique.

Significant progresses have been made in technological optimisation, as well as the characterization of some important mechanical properties and the structural changes during heat treatment or thermo-mechanical processing of the materials.

### TECHNOLOGY AND EQUIPMENT FOR INDUCTION HARDENING

#### FIELD DESCRIPTION

Surface treatments are important in order to improve exploitation characteristics of wear

stressed machine parts. Induction hardening is the proper treatment for cylindrical parts and plane surfaces, applied in serial manufacturing.

#### ACTIVITIES AND RESULTS

The research team developed and optimised surface hardening technologies by inductive treatment of different machine parts as: camshaft, guide conduit, inner cylindrical surfaces. A significant reduction of heating time and improve of exploitation characteristics of stud and railway switches was obtained.

#### INCREASE OF RELIABILITY ON DIFFERENT MACHINE PARTS BY SURFACE ENGINEERING

##### FIELD DESCRIPTION

Modern technology requires high quality machine parts with improved mechanical properties and reduced specific weight. Surface treatment as plasma nitriding and gas carburising on medium and high alloyed steels are meant to improve wear and fatigue strength, together with good behaviour in presence of dynamic stresses.

##### ACTIVITIES AND RESULTS

Advanced researches on plasma nitriding, gas carburising on medium and high alloyed steels, surface inductive treatment offer ready-to-use treatment technologies at industrial scale for high quality machine parts.

#### MODERN INVESTIGATION OF MATERIALS STRUCTURE AND PROPERTIES, IMAGE ACQUISITION AND PROCESSING IN OPTICAL AND ELECTRONIC MICROSCOPY

##### FIELD DESCRIPTION

Optical and electronic microscopy are investigation methods that provide complete information concerning the structure of materials. Computer aided acquisition and processing of images aloud the increase of the above methods' efficiency, for quantitative as well as qualitative measurements.

##### ACTIVITIES AND RESULTS

The improvement of the investigation equipment and the image acquisition and processing methods lead to the increase of the metallographic investigations results (image quality, measurements precision).

#### WELDING TECHNOLOGIES AND EQUIPMENTS (FUSION AND RESISTANCE)

##### FIELD DESCRIPTION

Electric arc welding of studs with ceramic ring, certification for welding technologies and welders training and authorization (for welding traditional materials as well as plastic materials), consulting and technical assistance for welding and weld control.

#### WELDING TECHNOLOGIES FOR SOLID STATE WELDING (FRICTION STIR WELDING)

##### FIELD DESCRIPTION

Solid state welding processes allows joining of a wide spectrum of materials, obtaining high quality welds with very low costs. Friction stir welding (FSW) is one of the state of the art processes from this family, on which are focused the researches from the center. Processing technologies allowed to obtain parts with gradient properties on their surfaces as a result of processing surface layers with FSP.

##### ACTIVITIES AND RESULTS

The researches carried out in the center focused on developing the technologies for friction stir welding (FSW) and also for friction stir processing (FSP) of materials, mainly of aluminium alloys, copper alloys and magnesium alloys.

#### MAIN PUBLICATIONS

##### BOOKS

1. Mihaela Popescu, *Basis of welding processes. Experimental themes*, Politehnica Publishing House Timisoara, p.188, ISBN 978-606-554-243-3;
2. Mihaela Popescu, *Joining of advanced materials*, Politehnica Publishing House Timisoara, p.667, ISBN 978-606-554-243-3;

##### PUBLISHED PAPERS

1. Mitelea Ion, Craciunescu Corneliu, *Investigations on joining surface hardened steels by friction welding*, Materials testing, Vol. 53, pp. 19-25, 6p, ISSN 025-5300, F. 0.335 (ISI);
2. Mitelea Ion, Dorohoi Claudia, Craciunescu Corneliu, *Microstructure oc Cu-Zn-Al shapes memory alloys joined by electric stored-energy welding*, Solid State Phenomena, pp. 208-213, 5p, ISSN 1012-0294, F. 0.493 (ISI);
3. Mitelea Ion, Craciunescu Corneliu, *Phase Transformation on friction welding of dissimilar thermochemical treated steels* Solid State Phenomena, pp. 916-921, 5p, ISSN 1012-0394, F. 0.493 (ISI);

4. Salai Maria, Milos Livius, Mitelea Ion, *Corrosion processes of welded joints used in equipment for burning special wastes*, Metalurgia International, vol. XVI, pp. 10-14, 4p, ISSN 1582-2214, F. 0.333 (ISI);
5. Craciunescu Corneliu, Miranda R., Silva R., Assuncao E., Braz F., *Laser interaction with NiMnGa ferromagnetic shape memory alloys*, Optics and Lasers in Engineering, vol. 49, Issue 11, pp. 1289-1293, 5p, ISSN 0143-8166, F. 1.606 (ISI);
6. Burca Mircea, Lita Marin, Cucuruz Roland, *TIG Riveting of Temperature Sheat Microprobe*, Materials Testing Materialprüfung, vol. 53, pp. 610, 6p, ISSN 978-3-446-42391-6, (ISI);
7. Burcă Mircea, Liță Marin, Cucuruz Roland, *TIG Riveting of Temperature Sheath Microprobe*, Material Testing – Material and Components, Tehnology and Application, vol. 53; pp. 610-616; 6p, ISSN 0025-5300, F. 0,35 (ISI);
8. Șerban Viorel Aurel, Buzdugan Dragos, Codrean Cosmin, Liță Marin, *Crystalization behavoir on Fe72Cr3Ga4P13Si5C3 bulk amophous alloy*, Metalurgia International, vol. 4; pp. 81-85; 4p, ISSN 1582-2214, F. 0,16 (SIS);
9. Lucian Constantin Hanganu, Sebastian Titus Duma, *Researches on steels destined to actuators specific for textile mechatronics systems*, Industria textilă, vol.62, nr. 6, pp. 325, ISSN 1222-5347, (ISI);
10. Todea Carmen, Balabuc Cosmin, Locovei Cosmin, Raduță Aurel, Filip Laura, *Root canal microleakage investigation after ER;YAG Laser-assisted treatment*, Laser in surgery and medicine, Phoenix, Arizona, vol. 43, supl. 23, pp. 984, 1, ISSN 0196-8092, F. 3 (ISI);
11. Vida-Simiti Ioan, Jumate Nicoalaie Bruj Emil, Sechel Niculina, Thalmaier Gyorgy, Nemes Dorel, Nicoară Mircea, *Metallic Foams Obtained from Nickel Based Superalloy Hollow Spheres*, Materials Science Forum, Vol. 672 (2011) pp 141-144, 4p, ISSN 1662-9752, (ISI);
12. Chicot D., Voda Mircea, Decoopman X., Șerban Viorel Aurel, Puchi-Cabrera E. S., Staia M. H., Codrean Cosmin, *Mechanical properties of an Al91Mn6Nd3 nanostructured alloy*, Materials Science and Engineering, 528, 7041, 11p, ISSN 0921-5093, F. 2.09, (ISI);
13. Șerban Viorel Aurel, Buzdugan Dragos, Codrean Cosmin, Liță Marin, *Crystalization Behaviour of Fe72Cr3Ga4P13Si5C3 Bulk amorphous Alloy*, Metalurgia International, vol. 16, pp. 85, 4p, ISSN 1582-2214, F. 0.154 (SIS);
14. Utu Dragos, Marginean Gabriela, Opris Carmen, Șerban Viorel-Aurel, *Corrosion and sliding wear behaviour of conventional and nanostructured WC-Co coatings*, Metalurgia International, vol. 16, pp. 21, 4p, ISSN 1582-2214, F. 0.154 (ISI);
15. I. Bordeasu, I. Mitelea, *Experiments regarding cavitation damage on biphasic brasses*, ModTech International Conference - New Face of TMCR Modern Technologies, Quality and Innovation, pp. 109-112, 4 p. ISSN 2069-6739, (ISI Proceedings);
16. C. Pogan, I. Secosan, I. Mitelea, W. Brandl, *The influence of electron beam scanning modus on the properties of titanium surfaces alloyed with tungsten carbide powder*, ModTech International Conference - New Face of TMCR Modern Technologies, Quality and Innovation, pp. 109-112, 4 p. ISSN 2069-6739, (ISI Proceedings);
17. C. Dorohoi, I. Mitelea, C. Craciunescu, *Research on the quality of Cu-Zn-Al shape memory alloys joint by electric resistance point – welding*, ModTech International Conference - New Face of TMCR Modern Technologies, Quality and Innovation, pp. 353-356, 4 p. ISSN 2069-6739, (ISI Proceedings);
18. R. M. Dobra, I. Mitelea, C. Locovei, *Improvement of wear resistance of mechanical parts using a duplex treatment*, ModTech International Conference - New Face of TMCR Modern Technologies, Quality and Innovation, pp. 329-332, 4 p. ISSN 2069-6739, (ISI Proceedings);
19. M. Dimian, I. Mitelea, I. Bordeasu, *Cavitation resistance of titanium alloys coated with oxides powder by plasma spraying and laser beam remelting*, ModTech International Conference - New Face of TMCR Modern Technologies, Quality and Innovation, pp. 329-332, 4 p. ISSN 2069-6739, (ISI Proceedings);
20. Ibolyka Bran, Radu Roșu, Mihaela Popescu, Carmen Opreș, Ion Grozav, *Optimization of biocompatible materials deposited by HVOF thermal spraying process*, Proceedings of Metal 2011, pp. 88, ISSN 978-80-87294-22-2, (ISI Proceedings);
21. Opreș Carmen, V.A. Șerban, I. Bran, Mihaela Popescu, *Sliding wear behaviour of cermet coatings deposited by thermal spraying*,

- Proceedings of ModTech 2011, pp. 781-785, 5p. ISSN 2069-6736, (ISI Proceedings);
22. I.Bran, R.Roșu, Mihaela Popescu, Carmen Opriș, *Properties of hydroxyapatite biocompatible layers deposited by two thermal spraying methods (APS and HVOF)*, Proceedings of ModTech 2011, pp. 129-133, 5p. ISSN 2069-6736, (ISI Proceedings);
  23. Tiberiu Medgyesi, Mihaela Popescu, Liviu Bereteu, Carmen Opriș, *Joining methods for thin sheets an coated thin sheets*, Proceedings of ModTech 2011, pp. 633-637, 5p ISSN 2069-6736, (ISI Proceedings);
  24. R. Moisa, Mihaela Popescu, Liviu Bereteu, Carmen Opriș, *Environmentprotection issues when using cored wire welding*, Proceedings of ModTech 2011, pp. 709-713, 4p. ISSN 2069-6736, (ISI Proceedings);
  25. R.Moisa, Mihaela Popescu, Liviu Bereteu, Carmen Opriș, *Comparative approach of tubular wire welding to other welding methods for assembly work on construction sites*, Proceedings of ModTech 2011, pp. 713-717, 4p. ISSN 2069-6736, (ISI Proceedings);
  26. Mihaela Popescu, Carmen Opriș, I. Bran, R. Roșu, *Thermal spraying approached based on the principle of sustainable development*, Proceedings of ModTech 2011, pp. 893-897, 4p. ISSN 2069-6736, (ISI Proceedings);
  27. Mihaela Popescu, Carmen Opriș, I. Bran, *Thermal spraying according to UE-s requirements for environment protection*, Proceedings of ModTech 2011, pp. 897-800, 4p. ISSN 2069-6736, (ISI Proceedings);
  28. Carmen Maria Loghin, Barbu Drăgan, Ștefan Grigoras, Sebastian Titus Duma, *Theoretical researches on textile spindle – ring centering specific to ring frames*, ModTech International Conference – New face of TMCR, Modern Technologies, Quality and Inovation, 6p. ISSN 2066 – 3919, (ISI Proceedings);
  29. Barbu Drăgan, Ștefan Grigoras, Daniela Ionescu, Sebastian Titus Duma, *Vibration monitoring strategies of gearboxes in mechatronics systems dedicated to textile machines*, ModTech International Conference – New face of TMCR, Modern Technologies, Quality and Inovation, 6p. ISSN 2066 – 3919, (ISI Proceedings);
  30. Ștefan Grigoras, Florin Pantilimonescu, Daniela Ionescu, Sebastian Titus Duma, *Textile equipment monitoring based on mechatronics concepts*, ModTech International Conference – New face of TMCR, Modern Technologies, Quality and Inovation, 6p. ISSN 2066 – 3919, (ISI Proceedings);
  31. Mihaita Peptanariu, Ștefan Grigoras, Daniela Ionescu, Sebastian Duma, *Ultrasonic cleaning device dedicated to textile machine components*, ModTech International Conference – New face of TMCR, Modern Technologies, Quality and Inovation, 6p. ISSN 2066 – 3919, (ISI Proceedings);
  32. V.A. Șerban, F.M. Cornea, Cosmin Codrean, D. Buzdugan, *Non-conventional technology for obtaining specimens of amorphous alloy ribbons for mechanical tests*, Proceedings of ModTech 2011, Vol. II, pp. 1001-1005, 4p. ISSN 2069-6736, (ISI Proceedings);
  33. V.A. Șerban, D. Buzdugan, Codrean Cosmin, I.D.Uțu, *Technology of obtaining bulk nanocrystalline alloys by devitrifications of Fe-Cr-Ga-P-Si-C bulk amorphous alloys*, Proceedings of ModTech 2011, Vol. II, pp. 997-1000, 4p. ISSN 2069-6736, (ISI Proceedings);
  34. A. Magda, Cosmin Codrean, I. D. Uțu, *Galvanized sheet metal welding using the cold metal transfer process*, Proceedings of ModTech 2011, Vol. II, pp. 33-36, 4p. ISSN 2069-6736, (ISI Proceedings);
  35. Radu Alexandru Roșu, Viorel Aurel Șerban, Violeta Tsakiris, Utu Dragos, Bran Ibolyka, Iosif Hulka, *Characterization of Titanium nitride layers obtained by HVOF thermal spraying method*, Proceedings of ModTech 2011, Vol. II, pp. 625-628, 4p. ISSN 2069-6736, (ISI Proceedings);
  36. Utu Dragos, Gabriela Marginean, Viorel-Aurel Serban, *The effect of electron beam remelting on the residual stress characteristics of MCrAlY coatings*, Proceedings of ModTech 2011, Vol. II, pp. 1129-1132, 4p. ISSN 2069-6736, (ISI Proceedings);
  37. Ion Mitelea, Dieter Schinle, Corneliu Craciunescu, Utu Dragos, *Modeling of connecting structure for pipe joining with application to Fe-Mn-Si shape memory alloy sleeves*, Proceedings of Metal 2011, 6p. ISSN 978-80-87294-22-2, (ISI Proceedings);
  38. Ion Mitelea, Daniel Ochian, Mircea Burca, Utu Dragos, *TIG Welding opportunities of bimetallic endless saw blades*, Proceedings of Metal 2011, 7p. ISSN 978-80-87294-22-2, (ISI Proceedings);
  39. Radu Alexandru Rosu, Viorel Aurel Șerban, Utu Dragos, Cosmin Locovei, Paula Sfarloaga, *Characterization of the titanium-hydroxyapatite biocompatible composite*

- layers deposited by HVOF thermal spraying method, Proceedings of Metal 2011, 6p. ISSN 978-80-87294-22-2, (ISI Proceedings);
40. Utu Dragos, Andrea Kellenger, Radu Rosu, Viorel-Aurel Serban, *Corrosion and sliding wear behaviour of high velocity oxygen fuel sprayed WC-Co coatings*, Proceedings of SGEM 2011, pp. 739, 6p, ISSN 1314-2704, (ISI Proceedings);
  41. Radu Alexandru Roşu, Viorel-Aurel Şerban, Utu Dragos, Mihaela Popescu, Alexandra Ioana Bucur, *Structural and mechanical characterization of titanium biocompatible layers deposited by HVOF thermal spraying method*, Proceedings of SGEM 2011, pp. 703, 6p, ISSN 1314-2704, (ISI Proceedings);
  42. C. Codrean, M. Lita, M. Burca, *The morphology and transformation of structure in resistance spot brazing of high speed steel to structural steel using amorphous brazing foils*, Revista de tehnologii neconventionale Nonconventional technologies review, Vol. XV, pp. 23, 4 p., 1454-3087, (BDI);
  43. Mircea Burca, Aurel Bena, Ioan Lucaciu, Geza Husi, *Aspects of root protection in welding*, Revista de tehnologii neconventionale Nonconventional technologies review, Vol. XV, pp. 25, 6p, ISSN 1454-3087, (BDI);
  44. D. Ochian, I. Mitelea, Mircea Burca, I.D. Utu, *Contributions regarding the material selection on endless saw blades*, Buletinul stiintific al Universitatii "POLITEHNICA" din Timisoara, Seria MECANICA, Vol. 56 (70), pag. 27, 6 pagini, ISSN 1224-6077, (BDI);
  45. I. Lucaciu, M. Burca, *Research on development of heterogennouswelding techhnologie*, Annals of Oradea University Fascicle of management and Technological Engineering, 2011, Volume X (XX), 2011, nr. 1, pag. 4.74-4.82, 9 p., ISSN 1583-0691, (BDI);
  46. Mircea Burca, Ioan Lucaciu, Puiu Caneparu, Cristian Belu, *Aspecte tehnologice privind sudarea MAG cu transfer prin scurtcircuit si in current pulsat a stratului de radacina*, Revista Sudura nr. 2/2011, An/Year XXI 2-2011, pp. 46, 5 p. ISSN 1453-0384, (BDI);
  47. C. Codrean, Marin Liţă, M. Burca, *Research and tehnology development in the field of the resistance brazing of carbide plates to metals using amorphous brazing foils*, Neconventional Tehnologies Review, nr. XII; pp. 23-26; 4p, ISSN 1454-3087, (BDI);
  48. M. Salai, L. Milos, I. Mitelea, *Corrosion evaluation of welded samples from ecological incinerators*, BSUPT, seria Mecanica, Vol. 56(70), ISSN 1224-6077, (BDI);
  49. Mihaela Popescu, R. Roşu, I. Bran, Carmen Opriş, *Applicability principles of thermal spraying*, Buletinul AGIR, nr. 2/2011, pp. 91-97, 6p, ISSN 1224-7928, (BDI);
  50. Mihaela Popescu, R. Roşu, *Probleme de protecție ambientală la sudarea cu sârmă tubulară*, Buletinul AGIR, nr. 2/2011, pp. 98-101, 4p, ISSN 1224-7928, (BDI);
  51. Cosmin Codrean, Marin Liţă, Mircea Burcă, *The Morphology and Transformation of Structure in Resistance Spot Brazing og High-Speed Steel to Structural Steel Using Amorphous Brazing Foils*, Nonconventional Technologies Review, XV (1), pp. 23, 4p, ISSN 1454-3087, (BDI);
  52. Iosif Hulka, Utu Dragos, Viorel-Aurel Serban, *Micro-scale behaviour of HVOF sprayed WC-Co(Cr)*, Annals of faculty engineering Hunedoara – International Journal of Engineering, nr. IX, pp. 61, 4p, ISSN 1584-2665, (BDI);
  53. Roşu Radu Alexandru, Şerban Viorel Aurel, Popescu Mihaela, Utu Dragos, *Properties of titanium nitride layers deposited by plasma thermal spraying and hvof method*, ANNALS of the ORADEA UNIVERSITY, X(XX), pp. 4.153, 6p, ISSN 1583 – 0691, (BDI);
  54. Eugen Pămîntaş, *Managing Information In Maintenance*, Annals of the Oradea University, Fascicle of Management and Technological Engineering, CD-ROM Edition, X (XX), Vol II, 4p, ISSN 1583-0691, (BDI);
  55. Eugen Pămîntaş, *How To Choose The Best Maintenance Strategy For A Company*, Annals of the Oradea University, Fascicle of Management and Technological Engineering, CD-ROM Edition, X (XX), Vol II, 4p, ISSN 1583-0691, (BDI);
  56. Tiberiu Medgyesi, Mihaela Popescu, Carmen Opriş, I. Bran, R. Roşu, *Problems when joining thin sheets*, Proceedings of the Annual Session of Scientific Papers "IMT Oradea" 2011, pp. 4.53, 8p, ISSN 1583-0691;
  57. Tiberiu Medgyesi, Mihaela Popescu, Carmen Opriş, Liviu Bereteu, *Sustainable development problems for galvanized sheets and their joining*, Proceedings of the Annual Session of Scientific Papers "IMT Oradea" 2011, pp. 4.92, 6p, ISSN 1583-0691;
  58. Raul Moisa, Mihaela Popescu, Carmen Opriş, I. Bran, M. Lavinia, *Ventilation systems at FCAW*, Proceedings of the Annual Session of

- Scientific Papers "IMT Oradea" 2011, pp. 4.61, 6p, ISSN 1583-0691;
59. Mihaela Popescu, I. Bran, R. Roşu, Carmen Opriş, *Gases and ventilation systems at thermal spraying*, Proceedings of the Annual Session of Scientific Papers "IMT Oradea" 2011, pp. 4.132, 7p, ISSN 1583-0691;
60. Mihaela Popescu, I. Bran, R. Roşu, Carmen Opriş, *Thermal spraying - interdisciplinary domain*, Proceedings of the Annual Session of Scientific Papers "IMT Oradea" 2011, issue 2, pp. 4.130, 10p, ISSN 1583-0691;
61. R. Roşu, V.A. Şerban, Mihaela Popescu, Dragoş Uţu, *Properties of titanium nitride layers deposited by plasma thermal spraying and HVOF method*, Proceedings of the Annual Session of Scientific Papers "IMT Oradea" 2011, issue 2, pp. 4.153, 6p, ISSN 1583-0691;
62. M. Pernevan, M.F. Dreucean, Mihaela Popescu, *Possibilities of using bast fibers in polymer biocomposites*, AGRO BULETIN AGIR(COPERNICUS), nr.2, an 3, pp. 164, 6p. ISSN 2066-6179;
63. R. Moisa, Mihaela Popescu, R. Roşu, L. Bereteu, L. Micu, *Environmental protection at tubular welding of agricultural machinery components*, AGRO BULETIN AGIR (COPERNICUS), nr.3, an 3, pp. 108, 9p. ISSN 2066-6180;
64. H. Daşcău, A. Sedmak, R. Roşu, Popescu Mihaela, *Friction stir welding applications in agriculture*, AGRO BULETIN AGIR (COPERNICUS), nr.3, an 3, pp. 118, 8p. ISSN 2066-6181;
65. T. Medgyesi, Popescu Mihaela, R. Roşu, L. Bereteu, L. Micu, *Realization brazing joints of the refrigeration installation components for food industry*, AGRO BULETIN AGIR (COPERNICUS), nr.3, an 3, pp. 126, 8p. ISSN 2066-6182;
66. M. Pernevan, C. Sirghie, M. F. Dreucean, Mihaela Popescu, I. Pernevan, *Considerations regarding bast fiber biocomposites utilizations*, AGRO BULETIN AGIR (COPERNICUS), nr.3, an 3, pp. 134, 6p. ISSN 2066-6183;
67. Mihaela Popescu, Radu Rosu, L. Micu, *Realization in welded storage tank with Applicability in agro domain*, AGRO BULETIN AGIR (COPERNICUS), nr.4, an 3, pp. 213, 4p. ISSN 2066-6184;
68. Mihaela Popescu, Utu Dragos, *Environmental protection issues by soldering in electronics*, Scientific Bulletin of the POLITEHNICA University of Timisoara, Transactions on Mechanics, vol.56, nr.1, pp. 69, 4p. ISSN 1224-6077;
69. Mihaela Popescu, Constantin Marta, *Problems posed by galvanized sheets applicability*, Scientific Bulletin of the POLITEHNICA University of Timisoara, Transactions on Mechanics, vol.56, nr.2, pp. 53, 4p. ISSN 1224-6077;
70. Roland Cucuruz, Sebastian Duma, Cosmin Locovei, *Some aspects of the restoration of furniture*, Scientific bulletin of the 'Politehnica' University of Timisoara, Transactions on Mechanics, Vol. 56(70), Iss. 1, pg. 43, ISSN 1224-6077;
71. Sebastian Duma, Cosmin Locovei, *Studies regarding the acquirement of hardness standard blocks for transmitting the Vickers hardness scale 270 ... 750 HV30*, Scientific bulletin of the 'Politehnica' University of Timisoara, Transactions on Mechanics, Vol. 56(70), Iss. 2, pg. 33, ISSN 1224-6077;
72. Iuliana Duma, Sebastian Duma, Cosmin Locovei, *Studies regarding the acquirement of hardness standard blocks for transmitting the Brinell 10/3000 HBW Hardness Scales*, Scientific bulletin of the 'Politehnica' University of Timisoara, Transactions on Mechanics, Vol. 56(70), Special Issue S1, pg. 25, ISSN 1224-6077;
73. A. Magda, Cosmin Codrean, *Dissimilar metal joining of aluminium alloys to steel by MIG brazing*, Scientific Bulletin of the 'Politehnica' University of Timisoara, 56(70)/S1, pp. 43, 6p. ISSN 1224-6078;
74. G. Melcioiu, V. A. Şerban, Codrean Cosmin, D. Buzdugan, F. M. Cornea, *Obtaining solder alloys from Sn-Ni-Cu-P family in ribbon form by melt-spinning method for electronic components soldering*, Scientific Bulletin of the 'Politehnica' University of Timisoara, 56(70)/S1, pp. 43, 6p. ISSN 1224-6078;
75. G. Melcioiu, C. Locovei, Codrean Cosmin, D. Buzdugan, F. M. Cornea, *Whiskers growths to printed circuit boards used in the automotive industry*, Scientific Bulletin of the 'Politehnica' University of Timisoara, 56(70)/1, pp. 25, 6p. ISSN 1224-6079;
76. Cosmin Codrean, I. D. Uţu, C. Opriş, I. Laza, *Studies on the degradation phenomena of some zones bz pipes steam boiler plant of SC Rovinari Energetic Complex*, Scientific Bulletin of the 'Politehnica' University of Timisoara, 56(70)/1, pp. 57, 4p. ISSN 1224-6080;
77. D. Toşa, Cosmin Codrean, *Overview of the assembly of the metallic carbides of the*

*cutting tools*, Scientific Bulletin of the „Politehnica” University of Timisoara, 56(70)/1, pp. 78, 4p. ISSN 1224-6081;

78. Ioan-Florin Secosan, Dragos Utu, Viorel-Aurel Serban, *The influence of process parameters on the characteristics of internal HVOF sprayed WC-CoCr cermet coatings*, Scientific Bulletin of the „Politehnica” University of Timisoara, 56(70)/ 1, pp. 37, 6p. ISSN 1224-6081;
79. Cosmin Codrean, Utu Dragos, Carmen Opris, Ioan Laza, *Studies on the degradation phenoma of some zones by pipes steam boiler plan of SC Rovinari energetic complex*, Scientific Bulletin of the „Politehnica” University of Timisoara, 56(70)/ 1, pp. 57, 6p. ISSN 1224-6081;
80. Iosif Hulka, Viorel Aurel Șerban, Utu Dragos, *Wear resistance of WC-10Co-4Cr coatings deposited by HVOF and HVOF of thermal spray processes*, Scientific Bulletin of the „Politehnica” University of Timisoara, 56(70)/2, pp. 13, 4p. ISSN 1224-6081;
81. Dumitru-Daniel Ochian, Ion Mitelea, Mircea Burca, Utu Dragos, *Contributions regarding the material selection on endless saw blades*, Scientific Bulletin of the „Politehnica” University of Timisoara, 56(70)/2, pp. 27, 6p. ISSN 1224-6081;
82. Cosmin Groza, Ion Mitelea, Utu Dragos, *Heterogeneous Ti-6Al-4V + X5CrNi18-10 joints welded by pulsed Nd-YAG laser*, Scientific Bulletin of the „Politehnica” University of Timisoara, 56(70)/2, pp. 49, 6p. ISSN 1224-6081;
83. Mihaela Popescu, Utu Dragos, *Environmental protection issues by soldering in electronics*, Scientific Bulletin of the „Politehnica” University of Timisoara, 56(70)/2, pp. 69, 4p. ISSN 1224-6081;
84. Radu Alexandru Roșu, Viorel-Aurel Șerban, Alexandra Ioana Bucur, Mihaela Popescu, Utu Dragos, *Characterization of titanium nitride layers deposited by reactive plasma spraying*, Journal for Technology of Plasticity, 36, pp. 17, 8p. ISSN 0354-3870;

#### **PhD THESIS – presented –**

1. *Theoretical and experimental researches on bicompatible layers deposited by thermal spraying*, Author: Ibolyka Vinczer, Scientific Coordinator: Prof.dr.eng. I.Cartiș.

#### **RESEARCH CONTRACTS**

1. Contract BS 7-046/2011, *Producerea hidrogenului din apa Marii Negre cu ajutorul pilelor de combustie cu sulfura - HYSULFCEL*, BS-ERA NET, Financer Uniunea Europeana 65%, Guvernul Romaniei 35%, Director N. Vaszilcin, Value UPT 90885.8 Lei;
2. Contract PN II-ID-PCE-2011-3-0837, *Sistem de Explorare pentru Optimizarea Actionarii cu Aliaje cu Memorie a Formei in Distributii Compozitionale*, Financer CNCS, Value 93387 Lei;
3. Contract 22-096/2008, *Sistem integrat pentru managementul riscurilor la echipamente și instalații din domeniul energetic*, Financer UEFISCDI, value 10000 Lei;
4. Contract 72-174/P2 2009, *Dezvoltarea unor metode si tehnici inovative de imbinare a materialelor eterogene prin sudare prin frecare cu element activ rotitor*, Financare UEFISCDI, Value 15000 Lei;
5. Contract 143/20.12.2010, *Design of a fixing device for processing stirring wheels*, Financare S.C. TRW Automotive safety systems s.r.l, Director C. Codrean, Value 4460 Lei;
6. Contract 16/2011, *Consulting and innovation services*, Financer SC NanoInteliform, Director C. Craciunescu, Value 100440 Lei;
7. Contract 17/2011, *RD services in nanoengineering*, Financer SC NanoInteliform, Director C. Craciunescu, Value 60264 Lei;
8. Contract 29/2011, *Training welders EN 281-1*, Financer S.C. AUTOHTON TIM SRL Timisoara, Director M. Burca, Value 1500 Lei;
9. Contract 55/12.4.2011, *Welding procedure for mechanized welding of beams – a comparative technical-economic study*, Financer SC Sudexpert SRL Timisoara, Director M. Popescu, Value 4960 Lei;
10. Contract 114/8.11.2011, *Reconditioning digging teeth for an excavator*, Financer SC Sudexpert SRL Timisoara, Director M. Popescu, Value 4960;
11. Contract 72/6.06.2011, *Trainign welders for welding copper bars*, Financer S.C. ELECTRIC SYS SRL Timisoara, Director M. Popescu, Value 2728 Lei;
12. Contract 66, *Consulting and investigations for material and technology quality*, Financer



- Mechanical Solutions, Director M. Nicoara, Value 1364 Lei;
13. Contract 105, *Researches on microstructure and properties of surface layers of parts from auto motive industry*, Financer Contitech Romania, Director M. Nicoara, Value 3224 Lei;
  14. Contract 31, *Researches on electronic components for auto motive industry*, Financer Continental Automotive, Director M. Nicoara, Value 19387,82 Lei;
  15. Contract 64, *Consulting on materials and technology quality for equipments used in treating residual waters*, Financer Aquatim, Director A. Raduta, Value 2480 Lei;
  16. Contract 38, *Researches on materials properties used in production*, Financer CRH, Director C. Locovei, Value 12788 Lei;
  17. Contract 116/14.11.2011, *Development of the working station for covering steering wheels*, Financer S.C. TRW Automotive Safety Systems S.R.L., Director C. Codrean, Value 5833 Lei;
- Prof. dr. eng. Ioan CARȚIȘ
  - Prof.dr.eng. Livius Miloș
  - Prof. dr. eng. Ion MITELEA
  - Prof. dr. eng. Victor BUDĂU
  - Prof. dr. eng. Roland Laurențiu CUCURUZ
  - Prof. dr. eng. Livius UDRESCU
  - Assoc. prof. dr. eng. Aurel RĂDUȚĂ
  - Assoc. prof. dr. eng. Mircea NICOARĂ
  - Assoc. prof. dr. eng. Bogdan RADU
  - Assoc. prof. dr. eng. C.M. CRĂCIUNESCU
  - Assoc. prof. dr. eng. Mihaela Popescu
  - Lecturer dr.eng. Dan Mălai
  - Lecturer dr. eng. Doru Dumbravă
  - Lecturer dr. eng. Mircea Burcă
  - Lecturer dr.eng. Daniel Țunea
  - Lecturer dr. fiz. Marin LIȚĂ
  - Lecturer dr. eng. Sebastian Titus DUMA
  - Lecturer dr.eng. Cosmin CODREAN
  - Lecturer dr. eng. Dragoș UȚU
  - Assist. dr. eng. Carmen OPRIS
  - Assist. dr. eng. Cosmin LOCOVEI
  - Assist. dr. eng. Aurelian Magda
  - Eng. Angela ZIMCEA

#### PATENTS

1. V.A. Șerban, Codrean Cosmin, D. Buzdugan, I.D. Uțu, patent RO 12602, Technology for obtaining bush shape magnetic sheelds from massive amorphouse alloys

#### RESEARCH TEAM

- Prof. dr. eng. Viorel Aurel ȘERBAN - Director
- Prof. dr. eng. Marin TRUȘCULESCU
- Prof. dr. eng. Voicu Safta

#### Contact

Dr. eng. Carmen OPRIS  
 Email: copris@eng.upt.ro  
 Tel: +40-256-403645

Dr. eng. Bogdan RADU  
 Email: bogdan.radu@mec.upt.ro  
 Tel: +40-256-403645

## RESEARCH CENTRE FOR QUALITY IN MECHANICAL TRANSMISSION, PRECISION MECHANICS AND MECHATRONICS

### GENERAL PRESENTATION

The research centre was founded in 11.05.2001 by the teaching staff of the Mechanisms and Machine Parts' Department. The research centre was recognized by CNCSIS as a C type centre with certificate number 71/CC-C/11.05.2001. From 2002, the research centre belongs to the Mechatronics' Department from „Politehnica” University of Timisoara.

The head of the research centre is **Prof. Dr. eng. Inocențiu Maniu**  
E-mail: Inocentiu.Maniu@mec.upt.ro

The major research domains are:

- Mechanical Transmission;
- Precision Mechanics;
- Mechatronics and Robotics

The main research topics are:

- Mechanisms;
- Machine design and parts for precision mechanics and mechatronics;
- Tribology;
- Instrumentation and metrology;
- Optical and opto-electronical apparatus;
- Biomedical apparatus (medical robotics and medical investigation);
- Robotics;
- Mechatronics;
- Simulation and artificial intelligence;
- Finite element analysis;
- Internet teleoperation;
- Domestic robots;
- Prosthesis;
- Sensors and Actuating systems;
- Computer Aided Design;
- Virtual reality;
- Computer Aided Quality, Quality Assurance, Quality Management.

The research centre was founded in order to:

- coordinate the scientific fundamental studies:
- mechanisms and mechanical transmission;
- robotics, precision mechanics and mechatronics;
- biomedical techniques; instrumentation and control;
- develop applied studies in different research projects for economical societies.

The research team disseminates the results in various publications: books, papers presented at national and international symposia, congresses etc.

### MAIN RESEARCH FIELDS

- Theoretical and experimental research of mechanisms and mechanical drives.

**Keywords:** gears, belts, linkages, cams, aviators, tribology, finite element method.

- Robotics

**Keywords:** robots, flexible fabrication systems, CIM systems, modelling/simulation and artificial intelligence.



- Studies and researches in the precision mechanics field and mechatronics.

➤ **Keywords:** measuring devices, transducers, metrology, quality assurance and optical systems.

- CAD, artificial intelligence and virtual reality.

**Keywords:** 3D modeling, virtual reality, finite element method.

### Researches in MECHANISMS AND MECHANICAL DRIVES

#### FIELD DESCRIPTION

- theoretical study, design and tests of special purpose mechanisms and mechanical drives, cams and linkages, mechanical variators, behavior of machine elements and mechanisms

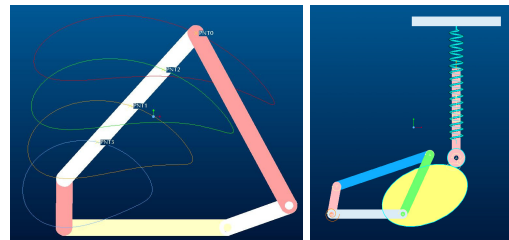

- tribological behavior of machine elements and mechanisms

ACTIVITIES AND RESULTS

- Collective competence used in computer aided design for general purpose or special mechanical drives (gears, belts, synchronic - belts etc.)

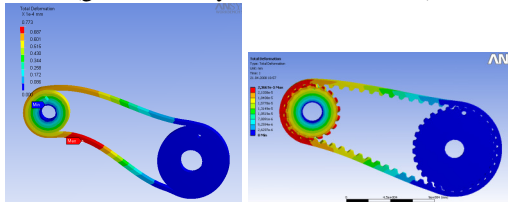

- Software for gears, cams and linkages design

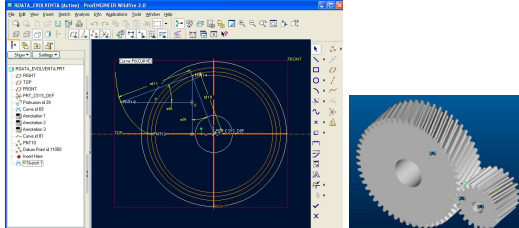

- Improvement of mechanisms and machine elements standardization. Studies for service life increase and reducing of wear

RESEARCH TEAM

- Prof.dr.eng. Dan PERJU
- Prof.dr.eng. Octavian GLIGOR
- Prof.dr.eng. Lucian MĂDĂRAS
- Prof.dr.eng. Voicu MESAROȘ-ANGHEL
- Prof.dr.eng. Inocențiu MANIU
- Prof.dr.eng. Arjana DAVIDESCU
- Prof.dr.eng. Mircea DREUCEAN
- Assoc.prof.dr.eng. Francisc IOANOVICI
- Assoc.prof.dr.eng. Erwin-Christian LOVASZ
- Assoc.prof.dr.eng. Iosif CĂRĂBAȘ
- Assoc.prof.dr.eng. Veronica ARGEȘANU
- Assoc.prof.dr.eng. Carmen STICLARU
- Assist.eng. Ioan COȚA
- Lect. Dr.eng. Dan MĂRGINEANU
- Lect. Dr.eng. Andreea DOBRA
- Lect. Dr.eng. Rodica MILITARU,
- Lect. Dr.eng. Mihaela JULA,
- Assist.eng. Adriana TEODORESCU.

RESEARCH OFFERS

- Computer aided design of special purpose mechanisms and mechanical drives
- Automatic equipment, reducers and gears
- Design and testing of cam and linkages
- Studies with finite element method.

Researches in **ROBOTICS AND MECHATRONICS**

FIELD DESCRIPTION

Fundamental and applied research in the field of the automation of flexible manufacturing processes, of computer aided design, as well as related to the component equipment's and techniques of flexible manufacturing systems.



ACTIVITIES AND RESULTS

- Fundamental, oriented and applied research aiming realization and industrial implementation of computer integrated manufacturing systems.



- Conception of flexible manufacturing modules, machining of medium – size parts (axles, bushings and prismatic parts).
- Flexible systems for manufacturing processes.

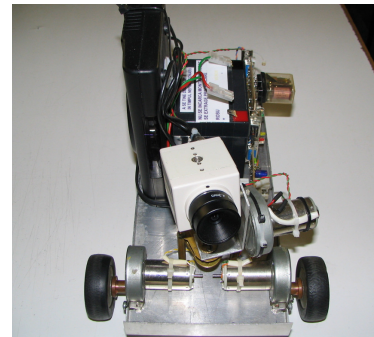

RESEARCH BENEFICIARIES

Ministry of Education, Ministry of Research and Technology, Fraunhofer Institute IPA Stuttgart, Germany, Technical University of Dresden



## RESEARCH TEAM

- Prof.dr.eng. George SAVII
- Prof.dr.eng. Corneliu RĂDULESCU
- Prof.dr.eng. Valer DOLGA



- Prof.dr.eng. Valeria VĂCĂRESCU
- Prof.dr.eng. Voicu MESAROȘ-ANGHEL
- Prof. dr. eng. Inocențiu MANIU
- Prof.dr.eng. Mircea DREUCEAN
- Assoc.prof.dr.eng. Nicolae DEHELEAN
- Lect. Dr. eng. Sanda GRIGORESCU
- Lect. Dr. eng. Anca POPA
- Lect. Dr. eng. Aurel DIACONU
- Lect. Dr. eng. Milenco LUCHIN
- Lect. Dr. eng. Marius MATEAȘ
- Assist. eng. Adrian RADU

## RESEARCH OFFERS

- On- and off-line diagnosis of flexible manufacturing systems components.
- Factory transports flexibility. Conception and industrial implementation of flexible manufacturing systems.
- Conception and different types of sensors. Modernizing methodologies of NC equipment's.
- Methodologies for integration of equipment purchased from heterogeneous manufacturer in unitary production systems.

### Researches in *PRECISION MECHANICS*

## FIELD DESCRIPTION

The research in the field of precision mechanics deals with the improvement of the measurement techniques, apparatus and precision mechanics equipment's, as well as quality assurance in mechatronics.

## ACTIVITIES AND RESULTS

- The analysis, synthesis and testing of apparatus and precision mechanics equipment's
- modern laboratory techniques and quality assurance
- CAQ.

## RESEARCH BENEFICIARIES

Direcția Sanitară Județeană Timiș, S.C. Optica Timișoara, INCDMF București, Ministry of

National Education (CNCSIS), Siemens Automotive VDO.



## RESEARCH TEAM

- Prof.dr.eng. Dan PERJU
- Prof.dr.eng. Octavian GLIGOR
- Prof.dr.eng. Ioan NICOARĂ
- Prof.dr.eng. George SAVII
- Prof.dr.eng. Valeria VĂCĂRESCU
- Prof.dr.eng. Valer DOLGA
- Prof.dr.eng. Arjana DAVIDESCU
- Assoc.prof.dr.eng. Corina GRUESCU
- Assoc.prof.dr.eng. Erwin-Christian LOVASZ
- Assoc.prof.dr.eng. Nicolae DEHELEAN
- Lect. Dr.eng. Marius MATEAȘ
- Lect. Dr.eng. Liana DEHELEAN
- Lect. Dr.eng. Adrian George RADU
- Lect. Dr.eng. Andreea DOBRA
- Assist.eng. Adriana TEODORESCU.



## RESEARCH OFFERS

- Modern techniques for metrological testing. Measuring instruments and equipment's for quality control.



- Optical and optoelectrical equipments. Bio-medical apparatus.

## PUBLICATIONS

### BOOKS

1. Davidescu A., Sticlaru C., *Metoda elementului finit in mecatronica. Aplicatii in Ansys Workbench*, tratat, Editura Politehnica, pp. 284, ISBN 978-606-554-274-7, [www.editurapolitehnica.upt.ro](http://www.editurapolitehnica.upt.ro).

### PUBLISHED PAPERS

1. Argesanu V., Kulcsar R., Borozan I., *Automotive mechanical face seal- Tribological Simulation*, Journal of the Balkan Tribological Association pp. 17, 12, ISSN 1310-4772, <http://scibulcom.net/home.html>, impact 1.104;
2. Argesanu V., Kulcsar R., Farkas I., *Calculation by Finite Element Method (FEM) of Temperature Distribution in the Components of a Mechanical Seal*, Journal of the Balkan Tribological Association, pp. 17, 7, ISSN 1310-4772, <http://scibulcom.net/home.html>, impact 1.104;
3. Adrian G. R., *Discussion on Nonlinear vibration of simply supported rectangular cross-ply plates* by Gajbir Singh, K. Kanaka Raju, G. Venkateswara Rao, and N.G.R. Iyengar [Journal of Sound and Vibration 142 (1990), 213–226, Journal of Sound and Vibration 330, pp. 2682, 8, ISSN 0022-460X, <http://www.journals.elsevier.com/journal-of-sound-and-vibration/> 2010 Impact Factor: 1.332 5-Year Impact Factor: 1.570 CNCSIS Relative Score: 1.84522;
4. Dolga V., Dolga L. *The structural synthesis of the parallel robots* *Mechanika*, 17(3), pp. 288-295, ISSN 1392-1207, 2029-6983, <http://zurnalas.mechanika.ktu.lt/>, impact 1.4;
5. Kulcsar R., Argesanu Veronica, Borozan I., Maniu I. *The human body behavior under vehicle vibrations*, Recent Researches in Automatic Control, 13th WSEAS International Conference on Automatic, Control, Modelling & Simulation (ACMOS'11), Lanzarote, Canary Islands, Spain, 27-29 May, 2011 pp. 252-258, 6, ISBN 978-1-61804-004-6, <http://www.wseas.us/conferences/2011/lanzarot/e/acmos/>;
6. Borozan I., Argesanu Veronica, Maniu I. Kulcsar R. *The energetic balance of the friction clutches used in automotive*, Recent Researches in Automatic Control, 13th WSEAS International Conference on Automatic, Control, Modelling & Simulation (ACMOS'11), Lanzarote, Canary Islands, Spain, 27-29 May, 2011, pp. 368-373, 5, ISBN 978-1-61804-004-7, <http://www.wseas.us/conferences/2011/lanzarot/e/acmos/>;
7. Draghici A., L. Ivascu, Vacarescu V., Dragoi G., *Occupational Risk and Health System Design Process*, 2011, *International Conference on Computer-Aided Design, Manufacturing and Management (CADMM 2011)*, ASME Publishing, ASME Publishing New York, USA, pp. 6, varianta electronic, [www.iiec-association.org/icimcs2011/](http://www.iiec-association.org/icimcs2011/);
8. Voinescu M., Davidescu A., *The influence of shoe heel height on the muscular activity of the thigh during walking*, *Proceedings of the International Conference E-Health and Bioengineering - "EHB 2011"* pp. 163, 4, ISSN 978-606-544-078-4, [www.bioinginerie.ro/ehb2011](http://www.bioinginerie.ro/ehb2011) IEEE, [http://www.ieee.org/conferences\\_events/conferences/conferencedetails/index.html?Conf\\_ID=19121](http://www.ieee.org/conferences_events/conferences/conferencedetails/index.html?Conf_ID=19121);
9. Dehelean N. M., Dehelean L.-M. *A Mirror Tracking Mechanism Book*, series: Mechanisms and Machine Science, 1, volume: 3, Mechanisms, Transmissions and Applications, Part 2, pp. 111-123, ISBN 978-94-007-2726-7, <http://metrapp-2011.mec.upt.ro>, SpringerLink, <http://springerlink.com>;
10. Gruescu C., Nicoara I., Busa E. *Loading Devices for Closed-loop Gear Test Stands*, First Workshop on Mechanisms, Transmissions and Applications, MeTrApp-2011, Timisoara, 3 oct - Mechanisms and Machine Science 3 pp. 281-288, ISSN 978-94-007-2726-7/2211-0984, <http://metrapp-2011.mec.upt.ro/>, Springer Link <http://www.springer.com/engineering/mechanical+eng/book/978-94-007-2726-7>;
11. Gruescu C. *Motion Laws of a Varifocal Objective working with a 1/2" CCD Camera*, First Workshop on Mechanisms, Transmissions and Applications, MeTrApp-2011, Timisoara, 3 oct - Mechanisms and Machine Science 3, pp. 133-140, ISSN 978-94-007-2726-7/2211-0984, <http://metrapp-2011.mec.upt.ro/Springer> Link

- <http://www.springer.com/engineering/mechanical+eng/book/978-94-007-2726-7>;
12. Lovasz E.-C., Perju D., Corves B., Brix T., Modler K.-H., Maniu I., Gruescu C.M., Lovasz A., and Ciupe V., *Multilingual Illustrated  $\mu$ -thesaurus in Mechanisms Science*, Series: Mechanisms and Machine Science, vol.3, Springer, pp. 47-58, 12, ISSN 978-94-007-2726-7, <http://www.metrapp-2011.mec.upt.ro>, Springer Link, <http://www.springerlink.com/>;
  13. Popa M., Popa A. S. *Optimizing cars` starting with acceleration control system*, Intelligent Systems and Informatics, pp. 281-285, 5, ISSN 978-1-4577-1973-8, [www.scopus.com](http://www.scopus.com);
  14. Neicu, M.-S., Savii, G., Benea, M.-C. *Simulated company as validation environment for the design methods and algorithms of informatics systems meant for the business environment* Recent Researches in System Science - Proceedings of the 15th WSEAS International Conference on Systems (Part of the 15th WSEAS CSCC Multiconference), pp. 180-184, ISSN: 1792-4235; ISBN: 978-1-61804-023-7, <http://www.wseas.us/conferences/2011/corfu/ics/Scopus> <http://www.scopus.com/>;
  15. Voicu C., Schmidt R., Lammen B., Mersch M., Maniu I. *Active bearing for Vibration Damping of Roller systems with Piezoelectric Actuators*, First Workshop on Mechanisms, Transmissions and Applications, MeTrApp-2011, Timisoara, 3 oct - Mechanisms and Machine Science 3, pp. 245-254, ISSN 978-94-007-2726-7/2211-0984, <http://metrapp-2011.mec.upt.ro/>, Springer Link, <http://www.springer.com/engineering/mechanical+eng/book/978-94-007-2726-7>;
  16. Tilneac M., Dolga Valer, *Extrinsic calibration of a multi-camera network used for individual plant phenotyping*, Proc. IEEE 7th Intern. Conf. on Intelligent Comp. Communication and Proc. ICCP 2011, pp. 353-359, ISSN 978-1-4577-1479-5, <http://www.scopus.com/results/results.url?sort=plf-f&src=s&st1=Dolga+V>;
  17. Moldovan F., Dolga Valer, Pop C., *Kinetostatic analysis of an articulated walking mechanism*, MeTrApp-2011, Mechanisms, Transmissions and Applications, Timisoara, pp.103-110, ISSN 978-94-007-2726-8 <http://metrapp-2011.mec.upt.ro/>, Springer Link, <http://www.springerlink.com/>;
  18. Dehelean N. M., Dehelean L.-M., *On Heliostat Mechanism Analyze*, Acta Technica Napocensis, Series: Applied Mathematics and Mechanics 54, Issue PSD, ISSN 1221-5872, pp. 63-68, Cluj-Napoca, Romania, 54, Issue PSD, 63-68 ISSN 1221-5872, [www.adems09.utcluj.ro/Eng/ADEMS\\_eng.html](http://www.adems09.utcluj.ro/Eng/ADEMS_eng.html);
  19. Zabava E. S. *Innovative reconfigurable multifunctional products using conventional materials*, Buletinul Institutului Politehnic din Iasi publicat de Universitatea Tehnica Ghe. Asachi din Iasi, Romania, seria MecanicaLVII (LXI), pp. 6, 1011-2855, [www.cm.tuiasi.ro/buletin/html/ro/index\\_bu.htm](http://www.cm.tuiasi.ro/buletin/html/ro/index_bu.htm);
  20. Mateas M., Ianosi E. *Flash flood warning system for small rural communities*, Analecta Technica Szegedinensia, 2011/1-2, pag.102-107, ISSN 1788-6392 [www.mk.u-szeged.hu](http://www.mk.u-szeged.hu);
  21. Voinescu M., Soares D., M. de Castro, Mendes E., Davidescu A., Machado L., *A study of moments acting on the tibia during gait in the active elderly population*, 28th Annual Conference of the International Society of Biomechanics in Sports Portuguese Journal of Sport Sciences 11 (Suppl. 2), 2011, pp. 575, 3, ISSN 1999-4168, <http://w4.ub.uni-konstanz.de/cpa/article/view/4900>;
  22. Pop C., Davidescu A., Moldovan F., *Object recognition using a smart camera*, The 10-th International Conference on Mechatronics and Precision Engineering, COMEFIM'10, Bucuresti, mai 2011 Romanian Review Precision Mechanics, Optics and Mechatronics, pp. 189, 4, ISSN 1584-5982, <http://www.comefim10.pub.ro/rezumat.pdf>;
  23. Dobra A., *Human Machine Interface and Interaction for General and Special Use*, The 10-th International Conference on Mechatronics and Precision Engineering, COMEFIM'10, Bucuresti, mai 2012, Mecatronica, nr. 2/2011, vol. 2, 7, 6, ISSN 1583-7653, <http://www.comefim10.pub.ro/rezumat.pdf>;
  24. Pecican A. H., Saftencu D., *Education for sustainable ecological design of students in their first study year*, The fourth edition of the International Conference on Engineering Graphics and Design, ICEGD 2011- "Sustainable Eco Design", Iasi, June, 2th-4th, 2011, Buletinul Institutului Politehnic din Iasi, tomul Ivii (Ixi), fasc. 6, 2011, Secția Construcții de mașini, pp.193, 8, ISSN 1011-2855, <http://www.sorging.ro/ro/articole/pagina-principal-icegd-2011>;
  25. Saftencu D., Pecican A. H., Walkovszky L. *Educational values of student professional competitions*, The fourth edition of the International Conference on Engineering Graphics and Design, ICEGD 2011- "Sustainable Eco Design", Iasi, June, 2th-4th, 2011, Buletinul Institutului Politehnic din Iasi, Tomul Lvii (Lxi), Fasc. 6, 2011, Secția Construcții de Mașini pp. 185, 8, ISSN 1011-2855; <http://www.sorging.ro/ro/articole/pagina-principal-icegd-2011>;

26. Ianosi E., *Considerations about efficient health care management systems*, EHB, Iasi, 24-26 Nov., Proceedings of EHB, pp. 515-518, 4, ISSN978-606-544-078-4, <http://www.bioinginerie.ro/>
27. Ianosi E., *Quality and risk management in dialysis*, EHB, Iasi, 24-26 Nov, Proceedings of EHB, pp. 519-522, 4, ISSN 978-606-544-078-4, <http://www.bioinginerie.ro/>;
28. Lovasz E.-Chr., Modler K.-H., Perju D., Modler N., Moldovan C., Margineanu D., *On the Size of Cam Mechanisms with Oscillating Roller Follower*, 13th World Congress in Mechanism and Machine Science, Guanajuato, México, versiune electronic, pp. 6, [http://somim.org.mx/conference\\_proceedings/author.html](http://somim.org.mx/conference_proceedings/author.html);
29. Lovasz E.-Chr., Perju D., Burkhard C., Torsten B., Modler K.-H., Lovasz A., Maniu I., Ciupe V., *Multilingual illustrated  $\mu$ -thesaurus of "mechanism" indexing terms*, 13th World Congress in Mechanism and Machine Science, Guanajuato, México versiune electronic, pp. 6, [http://somim.org.mx/conference\\_proceedings/author.html](http://somim.org.mx/conference_proceedings/author.html);
30. Lovasz E.-Chr., Perju D., Modler K.-H., Burkhard C., Torsten B., Döring U., Lovasz A., Maniu I., Ciupe V., *Erfahrungen aus der Lehre und Forschung kommen in die ThinkMOTION Datenbank*, 9. Kolloquium Getriebetechnik, Chemnitz Verlagshaus Monsenstein und Vannerdat OHG, pp. 16, ISSN 978-3-941003-40-8, <http://nbn-resolving.de/urn:nbn:de:bsz:ch1-qucosa-71264>;
31. Torsten B., Döring U., Brecht R., Reeßing M., Lovasz E.-Chr., *ThinkMOTION - Europeanas Tor in die Welt der Getriebe*, 9. Kolloquium Getriebetechnik, Chemnitz Verlagshaus Monsenstein und Vannerdat OHG, ISSN 978-3-941003-40-8, <http://nbn-resolving.de/urn:nbn:de:bsz:ch1-qucosa-71264>;
32. Modler N., Hufenbach W., Modler K.-H., Margineanu D., Lovasz E. C., Perju D., *Simulation Models for Compliant Mechanisms with Integrated Actuators*, 13th IFToMM World Congress Guanajuato, Mexico, versiune electronic, pp. 6, ISSN 978-607-441-131-7, [http://somim.org.mx/conference\\_proceedings/index.html](http://somim.org.mx/conference_proceedings/index.html);
33. Dreucean M., Sticlaru C., Davidescu A., *The validation of mechanostat theory in the case of petrochanteric fractures assisted by external fixed implants*, The 10-th International Conference on Mechatronics and Precision Engineering, COMEFIM'10, Bucuresti, mai 2011, Bul. St. Univ. Politehnica Bucuresti, Seria D, Mechanical Engineering., vol.73, Issue 2, 2011, p.71-78, ISSN 1454-2358, <http://www.comefim10.pub.ro/rezumat.pdf>;
34. Sticlaru C., Davidescu A., Dreucean M., *Aspects of contact region between bone and implant for different endoprosthesis types*, The 10-th International Conference on Mechatronics and Precision Engineering, COMEFIM'10, Bucuresti, mai 2011, Bul. St. Univ. Politehnica Bucuresti, Seria D, Mechanical Engineering., vol.73, Issue 2, 2011, p.79-86, ISSN 1454-2358; <http://www.comefim10.pub.ro/rezumat.pdf>;
35. Gorie N., Dolga V., *Biomechanics Recovery Systems for Persons with Disabilities*, Proc. Of Intern. Conf. on Innovations, MECAHITECH'11, vol.3. Romanian Review Precision Mechanics, Optics & Mechatronics, vol.3 (204), pp. 323-330, ISSN 1584-5982; <http://www.incdmtm.ro/mecahitech2011/documente/MECAHITECH'11%20Final%20Programme.pdf>;

#### GRANTS / RESEARCH PROGRAMS

1. *ThinkMOTION, Digital Mechanism and Gear Library goes European*, 250485/CIP-ICT-PSP-2009-3, FP7, European Commission Grant Agreement, 94443 Euro, Technische Universitaet Ilmenau - CO, Universidad del pais Vasco, Universitatea Politehnica din Timisoara, Rheinsch-Westfaelische Technische Hochschule, coord. Erwin-Christian Lovasz, Dan Perju, Inocentiu Maniu, George Savii, Iosif Carabas, Vacarescu Valeria, Gruescu Corina, Mesaros-Anghel Voicu, Argesanu Veronica, Dan Margineanu, Agneta Lovasz, Ivan Bogdanov, Dehelean Nicolae, Dehelean Liana, Sticlaru Carmen, Dobra Andreea, Zabava Eugen, Ciupe Valentin, Moldovan Cristian, Vatau Steliana, Ianosi Endre, Bereteu Liviu, Tucu Dumitru, Dolga Valer;
2. *International master on Robotics adaptive to labour market*, POSDRU 18/1.2/G/28382, 11999/26.05.2010, Universitatea Tehnica din Cluj-Napoca (coord.), HAMK University of Applied Science Finlanda, 167900 lei, coord. Maniu Inocentiu, Ciupe Valentin, Moldovan Cristian, Miclea Florian;
3. *FLEXFORM – on mechatronic platforms*, POSDRU/87/1.3/S/64069, 11999/ 26.05.10, 726,446.36 lei, U.Tehnica Cluj Napoca (coord.), Univ. Trans. Brasov, Univ Politehnica Bucuresti, Univ. Craiova, Univ. "Dunarea de jos" Galati, Univ. Tehnica "Gh. Asachi" Iasi, FestoSRL, coord. Dolga Valer, Dolga Valer, Dolga L., Hudac D., Ruset D., Dreucean M., Savii G., Davidescu A., Carabas I., Ciupe V., Vatau S., Moldovan C., Dobra A., Teodorescu A.;

4. *Dispositif european d'information et d'orientation a distance sur les metiers et qualifications en informatique et mecatronique*, Leonardo da Vinci 2009 -I FR1-LE005-07445, Leonardo da Vinci, Agentia europeana de educatie, 9,724lei, Coordonator UPT Stoicu-Tivadar Vasile, Dolga Valer, Dolga L., Iacob Adriana;
5. *Technical assistance and consulting regarding the optimisation of feroviar process* nr. 67/2011, SC Modelleisenbahn SRL Arad, 9114 lei, Margineanu Dan, Ciupe Valentin, Zabava Eugen;
6. *Investigations on the kineto-static analysis of compliant mechanisms using multi body simulation* BC 7/25.10.2010, TU Dresden Institut für Leichtbau und Kunststofftechnik, 11500 Euro, Lovasz Erwin, Margineanu Dan, Maniu Inocentiu, Ciupe Valentin;
7. *Research and consulting*, nr.S-524 / 29.09.2011, SC Continental Automotive Systems SRL Sibiu, 533.2 lei, coord. Sticlaru Carmen
8. *Research and consulting contract regarding the improvement of design activity in advanced CAD programs*, nr.655/16.04.2007 anexele 19, 20, 21 din 2011, SC Continental Automotive Romania SRL Timisoara 11500 lei, coord. Sticlaru Carmen.
7. Mondoc Alina, *Statistics models applied in studies on mobile robots working in environments with obstacles*, scientific supervisor: prof. dr. ing. Valer Dolga;
8. Vancu Alexandru, *Optimization of a foot prothesis*, scientific supervisor: prof. dr. ing. Valer Dolga;
9. Crăciun Andrei, *E-medicine systems*, scientific supervisor: prof. dr. eng. Mircea Dreucean;
10. Florea Cristina, *Investigation method of mechanical properties of materials*, scientific supervisor: prof. dr. eng. Mircea Dreucean;
11. Pernevan Silvia, *Studies upon biocomposites using liberian plants*, scientific supervisor: prof. dr. eng. Mircea Dreucean;
12. Pasca Ghorghe, *Modelarea si simularea sistemelor de fabricatie flexibile robotizate*, scientific supervisor: prof. dr. ing. Inocentiu Maniu;
13. Voicu Mariana Claudia, *Active damping of the flexible rolls from paper fabrication*, scientific supervisor: prof. dr. ing. Inocentiu Maniu;
14. Comşa Andrei, *Scanning automatization of an e-library*, scientific supervisor: prof. dr. ing. Inocentiu Maniu;
15. Borozan Ionuț, *Optimization of automated gear boxes*, scientific supervisor: prof. dr. ing. Inocentiu Maniu;

#### PhD STUDENTS

1. Teodorescu Adriana, *Contribution to modelling, simulation and testing of mechatronics systems*, scientific supervisor: prof. dr. eng. Dan Perju;
2. Sofronia Raluca, *Modelling of rheological materials in virtual reality*, scientific supervisors: prof. dr. eng. Arjana Davidescu, prof. dr. eng. George Savii;
3. Pop Cristian, *Artificial vision applied control of assembly robots*, scientific supervisor: prof. dr. eng. Arjana Davidescu;
4. Ciontos Ovidiu, *Nonlinearities in mechatronics systems and applications of inverted pendulum*, scientific supervisor: prof. dr. ing. Valer Dolga;
5. Moldovan Florentina, *Optimization of a walking mechanism*, scientific supervisor: prof. dr. ing. Valer Dolga;
6. Gorie Nina, *Studies upon ultrasonic sensors used in mechatronics*, scientific supervisor: prof. dr. ing. Valer Dolga;
16. Chis Violeta, *Contributions to optimisation of energetical network connections*, scientific supervisor: prof. dr. eng. George Savii;
17. Neicu Marian, *Methods and algorithms used in bussiness management*, scientific supervisor: prof. dr. eng. George Savii;
18. Lazareanu Andreea, *Studies upon special actuators*, scientific supervisor: prof. dr. ing. Valer Dolga;
19. Pop Adrian, *Modelling and simulation of SCARA Robot*, scientific supervisor: prof. dr. ing. Valer Dolga;

#### CONTACT

Assoc. Prof. Dr. eng. Erwin-Christian LOVASZ,  
 Head of Department, Bul. Mihai Viteazul Nr.1  
 300222 Timișoara, Romania  
 Tel: +40-256- 403551  
 E-mail: mecatronica@mec.upt.ro  
 Web: [www.mec.upt.ro/mecatronica](http://www.mec.upt.ro/mecatronica)



## RESEARCH CENTRE FOR THERMAL MACHINES AND EQUIPMENT, TRANSPORTATION AND POLLUTION CONTROL

### GENERAL PRESENTATION

This research centre was founded in 2001 (CNCSIS Certificate 70/CC/C/2001) and re-approved in 2006 (CNCSIS Certificate 14/12.IX.2006) by the National Council for University Research (CNCSIS), being recognized for the following main research fields:

- Thermal machines and equipment
- Environmental protection
- Transport vehicles

The research team includes the members of the founding chairs:

- ✓ Chair of Thermodynamics, Thermal Machines and Road Vehicles
  - ✓ Chair of Transportation Engineering,
- as well as associated researchers and PhD & master students.

Category	Under 35 years		Between 35 and 45 years		Over 46 years	
	Fem	Male	Fem	Male	Fem	Male
Total	3	9	3	12	3	20
PhD title holders	0	3	2	8	3	19
PhD students	3	7	1	3	-	1
Teaching personnel (full-time)	0	2	1	1	2	10
Research personnel (part-time) from RO/ from abroad	2/-	8/-	1/-	1/-	-/-	1/-

### CONTACT

**Director:** Prof. Dr. eng. habil Ioana IONEL

**Address:** 1, Bv. Mihai Viteazu  
300222 Timișoara

Tel. +40-256-403670

Fax: +40-256-403669

E-mail: [ioana.ionel@mec.upt.ro](mailto:ioana.ionel@mec.upt.ro)

Web page: <http://mmut.mec.upt.ro/>

### MISSION

- To promote its main expertise fields, by means of research projects & university curricula, by fundamental & applied, industrial, lab scaled & numerical simulations research, by offering

expertise & consultancy, by performing educational activities at undergraduate & graduate level, doctoral training, and post-university or expert training;

- To develop a self-financement budget by applying for research fundings, completion of basic equipment and additional activities (conferences, publications);
- To organize workshops, conferences, summer schools and other training modalities.
- To penetrate in the european research network and establish/apply/receive dissemination of high level curricula and R&D fields.
- To enlarge the thematic offer and activities.

**Researches in COMBUSTION PROCESS & COMBUSTION FACILITIES FOR CLASSIC AND RENEWABLE FUEL SOURCES, TECHNOLOGIES FOR THE REDUCTION OF POLLUTING IMPACT OF THE THERMAL MACHINES AND VEHICLES ON THE ENVIRONMENT, AIR QUALITY MONITORING**

**Keywords:** *classic and renewable fuels, waste, biomass, burners, boilers, combustion efficiency and control, pollutant emissions, air quality, thermal and environmental balances.*

### ACTIVITIES

- Laborator Analiza combustibili, Investigatii ecologice si Dispersia noxelor, acreditat RENAR LI 787,
- Environmental on line measurements, with attested methods (emissions and air quality), in real time data acquisition for CO, SO<sub>2</sub>, NO<sub>x</sub>, C<sub>m</sub>H<sub>n</sub>, combustion quality, including meteorological data,
- Hg measurements,
- Waste management (combustion) and flue gas cleaning,
- Optical & classical methods for air quality investigation,
- Optimization of energy production & transmission (power plants), using fossil and renewable fuels,
- Numerical simulation of the pollutant dispersion, using various statistical methods, regarding the stationary combustion installations (boilers, furnaces etc.) and mobile combustion installations (vehicles equipped

with ICEs: ISC3 View, Caline 3, Emisfac, Cal3qchr,

- Numerical experiments regarding the optimization of combustion installations by modelling of the velocity, temperature and concentration fields in the furnaces of boiler using the FLUENT program package,
- The ecological evaluation of the stationary and mobile combustion sources (burners, heaters, furnaces, ICEs) by experimental and theoretical researches, taking into consideration their toxicological effects;
- Energetic and ecological optimization of low quality coal, heavy oils and alternative fuels (such as domestic waste, biomass etc.) combustion process by experiments;
- Experimental researches regarding the performance indicators, safety and pollution level for small boilers (for individual heating systems);
- Thermal balances for simple or complex thermal installations, with proposals for optimization,
- Experimental researches regarding the Biogas production,
- Experimental researches regarding the Biofuel production,
- Experimental researches regarding the Biomass co-combustion, including numerical simulation,
- Experimental researches regarding the Waste co-combustion,
- Experimental researches regarding the CO<sub>2</sub> capture,
- Research on Advanced laser remote sensing system (LIDAR),

European Biomass Association (Belgium), Centre for Renewable Energy Sources (Greece), Utrecht University (Netherlands), University of Florence (Italy), Lithuanian Energy Institute (Lithuania), Imperial College of Science (UK), Centro da Biomassa para a Energia (Portugal), Energy Restructuring Agency (Slovenia), Andalusian Energy Agency (Spain) Francisc Popescu, Ioana Ionel, Adrian Eugen Cioabla, Nicolae Lontis, Gavrila Trif-Tordai.

2. Romanian Atmospheric Research 3D Observatory STVES - 2008/115266 NORWEGIAN COOPERATION PROGRAMME Noewegian gov. Ammount: 14624 euro, INOE (coordonator), UPT, Ionel Ioana, Popescu Francisc, L. Dungan, L. Calin, N. Lontis, G. Tordai, V. Cebruceam, I. Vetres, A. Cioabla, C. Ional, I. Macarie, M. Vasilescu, D. Gubencu.
3. Sustainable development for Banat region by means of academic education and scientific research & development in transboundary air quality monitoring issues MIS-ETC code-385 IPA EU + Romanian Gov. Ammount: 234832 euro, UPT (coordonator), Technical Faculty "Mihajlo Pupin" Zrenjanin Ionel Ioana, Popescu Francisc, Luisa Izabel DUNGAN, N. Lontis, G. Tordai, Dorin Lelea, Gelu Padure, Brateanu Gavril
4. EPOC - Energie pentru un oras curat 22131 PNCD-II PNCD-II, Ammount: 263.841 Ionel Ioana, Popescu Francisc, Luisa Izabel DUNGAN, Ionel Ciprian, Padure Gelu, Cioabla Adrian, Vetres Ioan, Balogh Ramon, Brateanu Gavril, Cebrucean Viorica, Lelea Dorin, Lontis Nicolae, Negrea Adina
5. Retea transnationala educationala privind orientarea si practica pentru cariera, corelate cu piata muncii, in societatea cunoasterii - PRACTICOR FSE - POSDRU POSDRU 48816, Ammount: 797664.11 RON. Ionel Ioana, Luisa Dungan, M. Vasilescu, Popescu Francisc, A. Han, D. Tucu, Ionel Ciprian, Ilare Bordeasu, R. Herman, L. Tulcan, I. Groza, M. Mocuta, W. Stefanescu, L. Bereteu, A. Stuparu.
6. Retea Nationala de formare CONTinua a CadreLOR Didactice din Invatamantul Preuniversitar Profesional si Tehnic - CONCORD FSE - POSDRU POSDRU 61397, Ammount: 176826.38 RON. Ionel Ioana, Ionel S., Popa M., Bucos M., Andone D., Vasiu R., Tanase D., Dungan L.
7. Măsurători termotehnice în vederea stabilirii nivelului de concentrații de noxe în canalul dublu de gaze de ardere, la cazanele de 420 t/h funcționand pe lignit Nr. 28, ROMAG TERMO Ammount: 63000,00 RON. Team

## RESULTS

### RESEARCH PROJECTS / CONTRACTS

1. EUBIONET - European bioenergy networks IEE-07-777SI2.499477 (WP3 + WP6) Intelligent Energy - Europe (IEE) EU Commission Ammount: 2784 euro VTT Technical Research Centre of Finland (coordonator), Danish Technological Institute (Denmark), Energy Centre Bratislava (Slovakia), Ekodoma (Latvia), Fachagentur Nachwachsende Rohstoffe e.V. (Germany), Swedish University of Agricultural Sciences (Sweden), "Politehnica" University of Timisoara (Romania), Brno University of Technology (Czech), Norwegian University of Life Sciences (Norway), Centre wallon de Recherches agronomiques (Belgium), BLTHBLuFA Francisco Josephinum (Austria),

- members: Ionel Ioana, F.Popescu, N.Lontis, Luisa DUNGAN
8. Cercetari privind determinarea emisiilor de COV (exprimat COT) evacuate in atmosfera la cabinele de vopsire Millenium ECO Air Nr. 23, S.C. ATON TRANSILVANIA SRL CARANI Ammount: 2048,38 RON. Team members: Ionel Ioana, F.Popescu, N.Lontis, Luisa DUNGAN
  9. Masuratori termotehnice reprezentative de emisii la instalatia de mixturi asfaltice si imisii in incinta unitatii Nr. 49, S.C DRUMURI MUNICIPALE TIMISOARA Ammount: 3057,17 RON. Team members: Ionel Ioana, F.Popescu, N.Lontis, Luisa DUNGAN
  10. Masuratori termotehnice trimestriale in vederea stabilirii nivelului de concentratii de noxe in canalul dublu de gaze de ardere al cazanului de 420 t/h functionand pe lignit Nr. 52, S.C CENTRALA ELECTRICA DE TERMOFICARE ARAD S.A. Ammount: 3229,63 RON. Team members: Ionel Ioana, F.Popescu, N.Lontis, Luisa DUNGAN
  11. Masuratori imisii PM 10 in incinta unitatii, in trei puncte distincte Nr. 59, S.C. CARPAT STICKS SRL TIMISOARA Ammount: 1051,77 RON. Team members: Ionel Ioana, F.Popescu, N.Lontis, Luisa DUNGAN
  12. Masuratori complexe privind determinarea emisiilor poluante in aer, la punctele de lucru, din Lugoj si Arad Nr. 65, SC HELLA ROMANIA SRL, TIMISOARA Ammount: 9076,00 RON. Team members: Ionel Ioana, F.Popescu, N.Lontis, Luisa DUNGAN
  13. Cercetari complexe privind determinareaemisiilor de pulberi in suspensie, specia PM10, in perimetrul unitatii Nr. 75, S.C. INTERCOLOR S.A. Ammount: 839,00RON. Team members: Ionel Ioana, F.Popescu, N.Lontis, Luisa DUNGAN
  14. Cercetari privind determinarea emisiilor de COV si PM10 in perimetrul unitatii Nr. 85, S.C. ALTO GRADIMENTO S.R.L. Ammount: 3775,63 RON. Team members: Ionel Ioana, F.Popescu, N.Lontis, Luisa DUNGAN
  15. Cercetari privind determinarea emisiilor de COV si pulberi in suspensie Nr. 87, S.C. DUQUEINE COMPOSITES S.R.L. Ammount: 1186,63 RON. Team members: Ionel Ioana, F.Popescu, N.Lontis, Luisa DUNGAN
  16. Pollution measurement services Nr. 117, CAMERA DE COMERT, INDUSTRIE SI AGRICULTURA TIMISOARA Ammount: 18496,34 RON. Team members: Ionel Ioana, F.Popescu, N.Lontis, Luisa DUNGAN
  17. Masuratori complexe privind determinarea emisiilor si imisiilor în aer Nr. 36, SC TRW AUTOMOTIVE SYSTEMS SRL Ammount: 4250,62 RON. Team members: Ionel Ioana, F.Popescu, N.Lontis, Luisa DUNGAN
  18. Masuratori termotehnice in vederea determinarii impactului asupra aerului a activitatii din unitatea industriala SC SMITFIELD PROD SRL Nr. 33, SC SMITFIELD PROD SRL Ammount: 23348,65 RON. Team members: Ionel Ioana, F.Popescu, N.Lontis, Luisa DUNGAN
  19. Masuratori termotehnice in vederea determinarii impactului asupra aerului a activitatii din unitatea industriala SC SMITFIELD PROD SRL Nr. 19, SC TMD FRICTION ROMANIA SRL Ammount: 4735,38 RON. Team members: Ionel Ioana, F.Popescu, N.Lontis, Luisa DUNGAN
  20. Masuratori termotehnice trimestriale in vederea stabilirii nivelului de poluare la cosurile de evacuare a gazelor reziduale Nr. 13, SC BERG BANAT SRL Ammount: 7331,00 RON. Team members: Ionel Ioana, F.Popescu, N.Lontis, Luisa DUNGAN

## PUBLICATIONS

### BOOKS

1. Blaga Petru, Minciuc Eduard, Temneanu Marinela, Donciu Codrin, Ionel Ioana, Lelea Dorin, Frigura Flaviu Masurarea marimilor neelectrice, Editura Academiei oamenilor de stiinta din Romania, Bucuresti.
2. Ionel Ioana, Popescu Fr., Apostol T. Tehnici de determinare a calitatii aerului, Editura Academiei Oamenilor de Stiinta din Romania, Bucuresti.
3. Gusa M., Ionel Ioana, Popa B., Ionescu C., Istrate M., Cenusă V. Surse regenerabile, Editura Academiei Oamenilor de Stiinta din Romania, Bucuresti.
4. Ionel Ioana, Popescu Fr., Lontis N., Lelea D., Pavlovici M., Djuric A., Pavlovici A. Banat air from theory to practice overview Editura SOLNESS, Timișoara.
5. Cioabla A., Ionel Ioana Biogazul, energie pentru viitor, Editura Politehnica Timisoara.
6. Badarau Rodica Contributii la studiul turbomasinilor axiale neintubate, Editura Politehnica Timisoara.
7. Fleser T., Ionel, Ioana, Vetres, I.(ed.) Proc. at 35<sup>th</sup> Cong. American Romanian Academy of Arts and Sciences (ARA): Science and Art in the Informatics Era proc. conf. Presses Internationales Polytechnique, Montreal

### PUBLISHED PAPERS

1. Francisc Popescu, Ioana Ionel, Nicolae Lontis, Laurentiu Calin, Luisa I Dungan, Air quality monitoring in an urban agglomeration, Romanian Journal of Physics, Volume: 56 Issue: 3-4 Pages: 495-506.
2. Francisc Popescu, Ioana Ionel, Camelia Talianu, Evaluation of air quality in airport areas by numerical simulation, Environmental

- Engineering and Management Journal , Volume: 10 Issue: 1 Pages:115-120.
3. Ionel Ioana, Nicolae D., Popescu Fr., Talianu C., Belegante L., Apostol G., Measuring air pollutants in an international romania airport with point and open path instruments, Romanian Journal of Physics, Volume: 3-4 Issue: 1 Pages: 507-509.
  4. Balogh R., Ionel Ioana, Experimental approach concerning the selective catalytic reduction of NO(x) for diesel engines of Romanian railway transport, Optoelectronics and advanced materials-rapid communications, Volume: 10 Issue: 1 Pages:1123-1129.
  5. Calinoiu D., Ionel Ioana, Trif-Tordai G. Analysis of aerosol optical thickness in Timisoara from aeronet observations Journal Stojarsstvo Volume: 5 Issue: 1 Pages: 291-301.
  6. CALINOIU D., Ionel Ioana, POPESCU Gr., TRIF-TORDAI G., NISULESCU C., VETRES I. RECENT SUNPHOTOMETRY MEASUREMENTS IN ROMANIA, AS PART OF THE AERONET NETWORK Revista Termotehnica Volume: 2 Issue: 1 Pages: 16-21.
  7. BALOGH M., Ionel Ioana, STEPAN S., RABL H., PFAFFINGER A. NO<sub>x</sub> REDUCTION USING SELECTIVE CATALYTIC REDUCTION (SCR) SYSTEM –  $\alpha$  VARIATION TEST Revista Termotehnica Volume: 2 Issue: 1 Pages: 22-27.
  8. Iacobescu F., Ionel Ioana EXPERIMENTAL COMPARATIVE RESULTS OF MAIN POLLUTANTS MONITORING FOR A SPARK IGNITION COGENERATION ENGINE FUELLED WITH LPG AND PETROL OPTOELECTRONICS AND ADVANCED MATERIALS-RAPID COMMUNICATIONS Volume: 2 Issue: 1 Pages: 16-21
  9. Cioabla A., Ionel Ioana, Vetres I. Research on noise reduction using different insulation materials in building passenger cars the 19th European Biomass Conference and Exhibition, Berlin, Germania Vol. 2 p. 1730-1735
  10. Lontis N., Ionel Ioana, Popescu Fr. Benefits and market forecasts for Biobutanol used in small scale chp systems the 19th European Biomass Conference and Exhibition, Berlin, Germania Vol. 2 p. 2340-2346.
  11. Ionel Ioana Bio-energy from short rotation coppice as source for the 2030 vision of district heating the 19th European Biomass Conference and Exhibition, Berlin, Germania 1 2744-2748
  12. Makra L., Matyasovszky I., Ionel Ioana, Popescu Fr. MODELLING AIR POLLUTION AT SZEGED, HUNGARY the 1st International Conference „Ecology of Urban Areas 2011”, Ecka-Zrejanin, Serbia Vol. 1 p. 19-28.
  13. Calinoiu D., Ionel Ioana, Trif-Tordai G. A STUDY FOR TRANSMISSION OF SUNLIGHT THROUGH THE ATMOSPHERE USING SUN PHOTOMETER the 1st International Conference „Ecology of Urban Areas 2011”, Ecka-Zrejanin, Serbia Vol. 1 p. 28-34.
  14. Cioabla A., Ionel Ioana, Popescu Fr., Lontis N., Dungan L. WOOD BIOMASS' ANAEROBIC FERMENTATION, SOURCE FOR RENEWABLE AND SUSTAINABLE ENER G the 1st International Conference „Ecology of Urban Areas 2011”, Ecka-Zrejanin, Serbia Vol. 1 p. 102-112.
  15. Mocuta E., Ionel Ioana, Horcher G., Dungan L., Fulga S. PRACTICAL TRAINING BETWEEN NECESSITY AND FACTS. PRACTICOR PROJECT PRESENTATION the 1st International Conference „Ecology of Urban Areas 2011”, Ecka-Zrejanin, Serbia Vol. 1 p. 480-484.
  16. Ionel Ioana, Pavlovic M., Popescu Fr., Lelea D., Jankovic S., Djuric A., Dungan L., Pavlovic A., Nikolic M. TRANSBOUNDARY AIR QUALITY MONITORING ISSUES IN ROMANIAN AND SERBIAN BANAT REGION the 1st International Conference „Ecology of Urban Areas 2011”, Ecka-Zrejanin, Serbia Vol. 1 p. 625-635.
  17. Calinoiu D., Popescu Fr., Nisulescu C., Ionel Ioana, Trif-Tordai G. Characteristics of aerosol types from sun photometer measurements the 7th INTERNATIONAL CONFERENCE ON INTEGRATED SYSTEMS FOR AGRI-FOOD PRODUCTION – SIPA'11, Nyíregyháza, Ungaria Vol. 2 p. 6-10.
  18. Cebrucean V., Ionel Ioana CO<sub>2</sub> capture. Experimental achievements and perspectives the 7th INTERNATIONAL CONFERENCE ON INTEGRATED SYSTEMS FOR AGRI-FOOD PRODUCTION – SIPA'11, Nyíregyháza, Ungaria Vol. 2 p. 14-16.
  19. Cioabla A., Dumitrel G., Ionel Ioana, Trif-Tordai G. Anaerobic fermentation in experimental applications at small scale the 7th INTERNATIONAL CONFERENCE ON INTEGRATED SYSTEMS FOR AGRI-FOOD PRODUCTION – SIPA'11, Nyíregyháza, Ungaria p. 17-21.
  20. Iacobescu F., Ionel Ioana Case study on main pollutants monitoring concerning Combusting LPG and petrol fuel in a generator with a spark ignition engine the 7th INTERNATIONAL CONFERENCE ON INTEGRATED SYSTEMS FOR AGRI-FOOD PRODUCTION – SIPA'11, Nyíregyháza, Ungaria Vol. 1 p. 45-50.

21. Lontis N., Popescu Fr., Ionel Ioana, Trif-Tordai G. Automatic system to control thermodynamic parameters of a pilot cogeneration plant the 7th INTERNATIONAL CONFERENCE ON INTEGRATED SYSTEMS FOR AGRI-FOOD PRODUCTION – SIPA'11, Nyíregyháza, Ungaria Vol. 3 p. 79-84.
22. Nisulescu C., Calinoiu D., Ionel Ioana New methods for determining SO<sub>2</sub> emissions the 7th INTERNATIONAL CONFERENCE ON INTEGRATED SYSTEMS FOR AGRI-FOOD PRODUCTION – SIPA'11, Nyíregyháza, Ungaria Vol. 2 p. 100-103.
23. Balogh R., Stepan D., Ionel Ioana Chemical pollution from diesel engines locomotives in traffic between railway stations on different gradients from the western part of Romania the 7th INTERNATIONAL CONFERENCE ON INTEGRATED SYSTEMS FOR AGRI-FOOD PRODUCTION – SIPA'11, Nyíregyháza, Ungaria Vol. 2 p. 152-156.
24. Stepan D., Balogh R., Ionel Ioana Noise control for railway structures the 7th INTERNATIONAL CONFERENCE ON INTEGRATED SYSTEMS FOR AGRI-FOOD PRODUCTION – SIPA'11, Nyíregyháza, Ungaria Vol. 2 p. 236-239.
25. Vetres I., Malan B., Ionel Ioana LIDAR and sunphotometer for aerosol investigation in Timișoara the 7th INTERNATIONAL CONFERENCE ON INTEGRATED SYSTEMS FOR AGRI-FOOD PRODUCTION – SIPA'11, Nyíregyháza, Ungaria Vol. 2 p. 258-263.
26. Dobrin M., Ionel Ioana Strategic directions for the development of the energy sector according to the new European policy the 7th INTERNATIONAL CONFERENCE ON INTEGRATED SYSTEMS FOR AGRI-FOOD PRODUCTION – SIPA'11, Nyíregyháza, Ungaria Vol. 2 p. 295-300.
27. Ionel Ioana, Tomescu C., Dobrin M. Economic, environmental and social evaluation of the LOTHECO concept in Romania, with application to potential independent energy producers the 7th INTERNATIONAL CONFERENCE ON INTEGRATED SYSTEMS FOR AGRI-FOOD PRODUCTION – SIPA'11, Nyíregyháza, Ungaria Vol. 2 p. 312-322.
28. Vetres I., Ionel Ioana, Bassim M. Aerosol Layers investigation by lidar systems, satellite images and trajectory models the 35th Annual Congress of the American Romanian Academy of Arts and Sciences, Timisoara, Romania p. 92-95.
29. Nisulescu C., Ionel Ioana, Calinoiu D. Remote sensing measurement technique for so<sub>2</sub> emissions the 35th Annual Congress of the American Romanian Academy of Arts and Sciences, Timisoara, Romania p. 102-105.
30. Ionel Ioana, Popescu Fr., Lontis N., Lelea D., Stoica V. Bio-Energy and the air quality the 35th Annual Congress of the American Romanian Academy of Arts and Sciences, Timisoara, Romania p. 106-115.
31. Balogh R., Ionel Ioana, Stepan D., Lontis N. Scr system applied on off road vehicle to reduce nox the 35th Annual Congress of the American Romanian Academy of Arts and Sciences, Timisoara, Romania p. 213-217.
32. Calinoiu D., Ionel Ioana, Vetres I., Trif-Tordai G. Comparative analysis of aerosol optical properties using sun photometry the 5th International Workshop on Optoelectronic Techniques for Environmental Monitoring - OTEM 2011, Magurele, Romania p. 56-61.
33. Vetres I., Ionel Ioana, Popescu Fr., Lontis N. Implementation of the multi-channel toli-lidar system for low atmosphere investigation on the timisoara region the 5th International Workshop on Optoelectronic Techniques for Environmental Monitoring - OTEM 2011, Magurele, Romania p. 101-107.
34. Nisulescu C., Ionel Ioana, Popescu Fr. Emission monitoring highlighted through remote sensing technique the 5th International Workshop on Optoelectronic Techniques for Environmental Monitoring - OTEM 2011, Magurele, Romania p. 211-218.
35. Ionel Ioana, Popescu Fr., Lontis N., Lelea D., Trif-Tordai G., Dungan L., Stoica V. Results in transboundary air quality monitoring the 5th International Workshop on Optoelectronic Techniques for Environmental Monitoring - OTEM 2011, Magurele, Romania p. 219-227.

#### **PhD THESIS**

*PhD supervisor: Prof.dr.eng. habil Ioana Ionel*

1. Eng. Apostol Gabriel, Air quality monitoring in the airport area,
2. Eng. Cebrucean Dumitru, Research on CO<sub>2</sub> capture,
3. Eng. Badescu Cicirone, EU Directive on Climate changes.

#### **PhD STUDENTS**

*PhD supervisor: Prof.dr.eng. Corneliu Ungureanu*

1. Eng. Alexandru Anghel C. GHENEA: *Contributions to the study of efficiency measures regarding the durable development of Ișalnița Power Plant*
2. Eng. Florica TUDOR: *Contributions regarding the diminution of environmental pollution due*

*to the ash produced at the lignite combustion at Turceni Power Plant*

3. Eng. Marius MARIN: *Contributions regarding the diminution of environmental pollution due to gaseous pollutants produced due to the lignite combustion at Turceni Power Plant*
4. Eng. Vasile GRUESCU: *Contributions regarding the ergo-technology of domestic and street waste*
5. Eng. Victor EBETIUC: *Studies and researches regarding the efficient production and distribution of thermal energy in Turnu Severin city*
6. Marian Gabriel MILI: *Contributions regarding the modernization of existing energetic units using the combined cycle steam-gas with parallel disposition*
7. Eng. Marian DOBRIN: *Contributions regarding the elaboration of a methodology of evaluation of technical and economic efficiency of energetic projects in the view of promoting the funding*

*PhD supervisor: Prof.dr.eng. habil Ioana Ionel*

1. Eng. Lucia VARGA: *Studies and researches regarding the air quality in Bihor county*
2. Eng. Florin IACOBESCU: *Theoretical and experimental studies regarding the reduction of pollutants concentration for internal combustion engines and the study of the effects on air by applying novel technologies*
3. Eng. Cebrucean Dumitru, *Theoretical and experimental studies of the CO<sub>2</sub> capture from the flue gases from the stationary facilities*
4. Eng. Balog Ramon, *NO<sub>x</sub> reduction applied to diesel engines with co-combustion from railway vehicles.*
5. Eng. Veters Ioan, *Atmospherically investigations with Lidar systems..*
6. Eng. Rosca Ciprian, *Ecological aspect of the transportation and sustainable development.*
7. Eng. Tomescu Claudia, *Implementation of the pollution legislation upon the energy production of Romania.*
8. Eng. Calinoiu Delia, *Research regarding photovoltaic solar panels*
9. Eng. Nisulescu Catalin, *Contribution to improvement of the LIDAR systems in Timisoara*
10. Eng. Cebrucean Viorica, *Numerical simulation on CO<sub>2</sub> absorption process.*

11. Eng. Maria Apascaritei, *Research in area of air quality*
12. Eng. Malan Bassim, *Study on air quality in desert storm*
13. Eng. Goanta Adrian, *Thermodynamics process in combustion facilities*
14. Eng. Magda Adrian, *Thermodynamics process in steam boilers*

#### **Post-doc STUDENTS**

- Dr.eng. Nicolae Lontis, *Research on co-generation facilities,*
- Dr. Eng. Adrian Irimescu, *Research on air pollution from IC engines,*
- Dr. Eng. Cioabla Eugen Adrian, *Research on biogas production management*

#### **RESEARCH TEAM**

➤ Prof.dr.eng. Corneliu UNGUREANU

- Prof.dr.eng.habil Ioana IONEL
- Assoc.prof.dr.eng. Oprisa Paul Dan Stanescu
- Assoc.prof.dr.eng. Dorin LELEA
- Lect. dr. eng. Francisc POPESCU
- Ass. Eng. Gavrilă TRIF-TORDAI
- Dr.eng. Nicolae LONTIS
- Eng. Lucia VARGA, PhD student
- Eng. Florin IACOBESCU, PhD student
- Eng. Rosca Ciprian, PhD student
- Eng. Marian Gabriel MILI, PhD Student
- Eng. Marian DOBRIN, PhD Student
- Eng. Carmencita CONSTANTIN, PhD Student
- Eng. Veters Ioan, PhD Student
- Eng. Cebrucean Viorica, PhD Student
- Eng. Maria Apascaritei, PhD Student
- Dr. Eng. Laurentiu Calin
- Dr. Eng. Cioabla Eugen Adrian
- Dr. Eng. Adrian Irimescu
- Eng. Gavril Brateanu

#### **CONTACT**

Prof. Dr. eng. habil Ioana IONEL  
 Faculty of Mechanical Engineering  
 1 Mihai Viteazul Bv.  
 Timișoara, RO-300222, Romania  
 Tel.: +40-256-403670, Fax: +40-256-403669  
 E-mail: ionel\_monica@hotmail.com  
[ioana.ionel@mec.upt.ro](mailto:ioana.ionel@mec.upt.ro)  
 Web: <http://energieregen.mec.upt.ro/>  
[www.mediu.ro](http://www.mediu.ro)

#### **Researches in INTERNAL COMBUSTION ENGINES (ICEs) AND FUEL CELLS**

**Keywords:** *spark-ignition engine, diesel engine, heat flow, carburetor hot spot, compression rate,*

*heat exchanger, mixture formation, combustion process, numerical evaluation of pollutants, fuel cell, energy use reduction, emission reduction*

#### Activities:

- experimental researches regarding the operation, the level of pollution and energetic performance of ICEs using gaseous fuels
- experimental researches regarding the endurance and reliability qualities of ICEs
- experimental researches regarding the thermo-mechanical stresses in the ICEs sub-units
- numerical evaluation of the mixture formation and the combustion process, based on the fuel drops evolution (Diesel engines)
- numerical evaluation of pollutants
- calculation of the energetic and ecological performances for ICEs using gaseous fuels
- studies regarding the use of fuel cells to reduce energy use and emissions for transportation and stationary power applications

#### PERSPECTIVES

Development of the Laboratory for Processes in Internal Combustion Engines

Development of the Multifunctional Lab for Road Vehicles

#### PHD STUDENTS

*PhD Supervisor: Prof.dr.eng. Daniel IORGA*

1. Eng. Radu HORATIU: *Studies and researches regarding the conditions for mixture formation through injection in the valve port of a spark-ignition engine, related to the engine performances and the level of stresses*
2. Eng. Călin MOLDOVEANU: *Researches regarding the energetic performances and the pollution reduction for a direct injection diesel engine using a system of high pressure injection pressure*
3. Eng. Daniel PICIOREA: *Contributions to the adjustment of an injection system to use unconventional liquid fuels for a direct injection diesel engine*
4. Eng. Ludovic BAKOS: *Contributions to the analysis of the causes and effects of the road accidents from Arad county and methods of limiting it*

#### RESEARCH TEAM

- Prof.dr.eng. Daniel IORGA
- Prof.dr.eng. Traian RAICA
- Assoc.prof.dr.eng. Liviu MIHON
- Lect.dr.eng. Gelu PADURE

- Lect.dr.eng. Sorin HOLOTESCU
- Lect. Dr.eng. Gheorghe POP
- Lect. Dr.eng. Arina Speranța NEGOIȚESCU
- Lect. Dr. eng. Virgil STOICA,
- Lect.dr.eng. Daniel OSTOIA,
- Dr. Eng. Adriana TOKAR,
- Dr. Eng. Adrian IRIMESCU,

#### CONTACT PERSONS

Prof.dr.eng. Daniel IORGA ([diorga@mec.upt.ro](mailto:diorga@mec.upt.ro))  
 Assoc.prof.dr.eng. Liviu MIHON ([mihon@mec.upt.ro](mailto:mihon@mec.upt.ro))  
 Lect. Dr.eng. Sorin HOLOTESCU ([holos@mec.upt.ro](mailto:holos@mec.upt.ro))

Address: Faculty of Mechanical Engineering  
 1 Mihai Viteazul Bv., Timișoara, 300222

Tel.: +40-256-403661

Fax: +40-256-403520, +40-256-403669

#### Researches in ENHANCEMENT AND CONTROL OF HEAT AND MASS TRANSFER FOR THERMAL EQUIPMENTS AND ELECTRONIC COOLING, THERMAL NETWORKS

**Keywords:** *heat transfer enhancement, heat transfer control, magnetizable nanofluids, nanoscale systems, bubble dynamics, electronic equipment cooling, thermal network, heat exchangers, refrigerating machines, heat pumps, thermal phenomena, microchannel heat transfer*

#### ACTIVITIES

- researches regarding the optimization of heat exchangers
- theoretical studies concerning the heat transfer enhancement by means of numerical simulations
- researches regarding the mechanism of multi-phase heat transfer control by applying a magnetic field to a magnetizable nanofluid
- theoretical studies concerning the behaviour thermodynamic systems by molecular dynamics and Monte Carlo simulations
- electronic equipment cooling
- optimization of urban thermal networks
- Advance numerical modeling in heat transfer
- Micro- and nano-scale heat transfer and fluid flow

#### RESULTS

##### RESEARCH CONTRACTS

1. Nanofluid magnetic – un nou mediu izolator și de răcire pentru transformatoarele electrice (Magnetic Fluid – New Insulated and Cooling Medium for Power Transformers) – MAFINCO MNT 7-018/2009 FP7, ERA-NET UEFISCDI Ammount: 59000,

- Romania:coordonator-UPT, parteneri: Academia Romana Filiala Timisoara si ROSEAL S.A. Odorheiu Secuiesc; SLOVACIA: coordonator international: Academia de Stiinte a Slovaciei, parteneri: Universitatea Tehnica din Kosice, Electrotechnical Research and Desig Stoian Floriana Daniela - director proiect, Holotescu Sorin - membru in echipa de management a proiectului, Marinica Oana, Dobra Andreea, Han Adelina, Pop Gheorghe, Giula George.
2. Cercetarea fundamentala a fenomenelor termice si fluidodinamice din micro-dispozitive de racire 670/2009 PCE-IDEI UEFISCDI Ammount: 199632 - Lelea Dorin, Ioan Laza, Liviu Mihon, Arina Negoitescu, Adrian Cioabla, Catalin Nisulescu
  3. Contract nr.73/09.06.2011: Analiza conditiilor existente, comparativ cu cele necesare, pentru implementarea si utilizarea unui sistem de management pe baza de risc.Beneficiar:S.C.S.N.T.G.N.Transgaz S.A. Medias.Valoare:248.000 RON.

#### BOOKS

1. Lelea Dorin, Cioabla Adrian, Nisulescu Catalin Transfer de caldura cu aplicatii in microcanale, Editura Politehnica Timisoara.

#### PUBLISHED PAPERS

1. Lelea Dorin, The performance evaluation of Al<sub>2</sub>O<sub>3</sub>/water nanofluid flow and heat transfer in microchannel heat sink, International Journal of Heat and Mass Transfer 54(17-18), p. 3891-3899.
2. Lelea Dorin, Cioabla Adrian, The developing heat transfer and fluid flow in microchannel heat sink with viscous heating effect Heat and Mass Transfer 47, p. 751-758.
3. Lelea Dorin, Nisulescu Catalin, The micro-tube heat flow of water based Al<sub>2</sub>O<sub>3</sub> nanofluid with viscous dissipation International Communications in Heat and Mass Transfer 38(6), p. 704-710.
4. Lelea Dorin, Laza Ioan, Mihon Liviu, The Microchannel Cooling with Dielectric Fluids Strojartstvo 53(5), p. 325 – 330.
5. Holotescu S., Stoian F. D., Marinica O., Kubicar L., Kopcanski P., Timko M., Utilization of the magnetogrulometric analysis to estimate the thermal conductivity of magnetic fluids Journal of Magnetism and Magnetic Materials 323, p. 1343-1347.
6. Holotescu S., Stoian F. D. Prediction of particle size distribution effects on thermal conductivity of particulate composites

- Materialwissenschaft und Werkstofftechnik 42, p. 379-385.
7. Paul-Dan Opriș-a-Stănescu, Ioan Laza Operation of IP-01 Type Boiler with Alternative Fuels Termotehnica / AGIR Anul XV, nr. 1S/2011, p 13 - 16.
  8. Fl. Mărcuț, M. Jădăneanț Determinarea experimentală a performanțelor generatorului de aer cald tip A20 A XI-a Conferință națională "profesorul Dorin Pavel" Sebeș 2011 Știință și Inginerie, Vol.XX, Ed. AGIR, 2011 p. 233 – 238.
  9. A. Birlan, M. Jădăneanț Studiu experimental cu privire la apariția urechilor la ambutisarea pieselor cilindrice A XI-a Conferință națională "profesorul Dorin Pavel" Sebeș 2011 Știință și Inginerie, Vol.XX, Ed. AGIR, 2011 p. 431 – 436.
  10. R. Petriko, M. Jădăneanț Studiu de caz asupra sistemelor de recuperare a energiei la frânare, utilizate în cazul autovehiculelor hibride A XI-a Conferință națională "profesorul Dorin Pavel" Sebeș 2011 Știință și Inginerie, Vol.XX, Ed. AGIR, 2011 p. 539 – 544.
  11. R. Petriko, M. Jădăneanț Prevenirea riscurilor în activitățile de mentenanță Simpozionul "Mentenanța în condiții de securitate", Cluj Napoca 17-19.X.2011 Prevenirea riscurilor în activitățile de mentenanță, Editura Mega, Cluj Napoca, 2011 p. 157 – 162.
  12. M. Jădăneanț, A. Birlan Probleme de mentenanță în procesul de ambutisare la rece Simpozionul "Mentenanța în condiții de securitate", Cluj Napoca 17-19.X.2011 Prevenirea riscurilor în activitățile de mentenanță, Editura Mega, Cluj Napoca, 2011 p. 267 – 273.
  13. Fl. Mărcuț, M. Jădăneanț Generatorul de aer cald tip A20 - mentenanță Simpozionul "Mentenanța în condiții de securitate", Cluj Napoca 17-19.X.2011 Prevenirea riscurilor în activitățile de mentenanță, Editura Mega, Cluj Napoca, 2011 p. 273 – 278.

#### PhD THESIS

PhD supervisor: Prof.dr.eng. Mihai JĂDĂNEANȚ

1. Eng. Marcuț Florin, Fuel combustion in independent heaters

#### PhD STUDENTS

PhD supervisor: Prof.dr.eng. Mihai NAGI

1. Eng. Catrina Mihai Cezar, Energy reduction in electric locomotive
2. Eng. Carabas Daniel, Research on compact heat exchangers



3. Eng. Ander Claudiu, Pollution reduction on road vehicles
4. Eng. Tiberius Stanciu: Researches regarding the use of shell type of tubes for the construction of compact heat exchangers
5. Eng. Buculei Mihaela, Heat mass transfer

*PhD supervisor: Prof.dr.eng. Mihai JĂDĂNEANȚ*

1. Eng. Petrico Remus Mihail: Industrial engineering
2. Eng. Patan Traian, Transportation logistics and system Ro-La
3. Eng. Bacala Miodrag, Internal combustion engines and non-conventional fuels
4. Eng. Birlan Adrian, Industrial engineering

#### RESEARCH TEAM

- Prof.dr.eng. Mihai NAGI
- Prof.dr.eng. Mihai JĂDĂNEANȚ
- Prof.dr.eng. Gavril CREȚA
- Assoc.prof.dr.eng. Floriana D. STOIAN
- Assoc.prof.dr.eng. Liviu MIHON
- Assoc.prof.dr.eng. Ioan LAZA
- Assoc.prof.dr.eng. Dorin LELEA
- Lect. Dr.eng. Gheorghe POP
- Lect. Dr.eng. Arina NEGOIȚESCU
- Lect.eng. Virgil STOICA
- Eng. Petrico Remus Mihail
- Eng. Patan Traian
- Eng. Bacala Miodrag
- Eng. Birlan Adrian
- Eng. Catrina Mihai Cezar
- Eng. Carabas Daniel
- Eng. Ander Claudiu
- Eng. Tiberius Sanci
- Eng. Buculei Mihaela

#### CONTACT

Prof.dr.eng. Mihai Nagi ([nagi@mec.upt.ro](mailto:nagi@mec.upt.ro))  
 Prof.dr.eng. Mihai Jădăneanț ([mihaij@mec.upt.ro](mailto:mihaij@mec.upt.ro))  
 Assoc.prof.dr.eng. F. D.Stoian ([floriana.stoian@mec.upt.ro](mailto:floriana.stoian@mec.upt.ro))  
 Assoc.prof.dr.eng. Ioan Laza ([laza@mec.upt.ro](mailto:laza@mec.upt.ro))  
 Assoc.prof.dr.eng.Dorin Lelea ([ldorin@mec.upt.ro](mailto:ldorin@mec.upt.ro))

Faculty of Mechanical Engineering  
 1 Mihai Viteazul Bv.  
 Timișoara, RO-300222, Romania  
 Tel.: +40-256-403661, Fax: +40-256-403520  
 Web Page: [www.mec.upt.ro/~tmtar/](http://www.mec.upt.ro/~tmtar/)

**Researches in RAILWAY DESIGN,  
 ESTIMATION OF ENERGY CONSUMPTION  
 OF TRAINS, RAILWAY TRANSPORT  
 SYSTEMS**

**Keywords:** *railway traction, traction estimation, combustible and electric energy consumption, energy saving, pollution, multimodal transport, freight terminals, RO – LA transport, FERRY –*

*BOAT, containers special train, railway conveyance of material.*

#### ACTIVITIES

Estimation of combustible and electric energy consumption and the influences of parameters such as: profile of wheel and rail, constructive and functional characteristics of locomotives and wagons, train driving type and others

Design of railway parts: bogies, wheelsets, dampers, rolling equipment

Elaboration the solving methodology for train's movement equation by using Runge-Kutta integration method

Elaboration of a computer code for traction calculation, combustible and energy consumption

Multimodal transport: RO - LA transport, FERRY - BOAT and containers special train  
 Analysis of the transport types with respect to conveyance of material, quantity, periods of time, transports relations

#### RESULTS

##### RESEARCH CONTRACTS

1. Cercetări privind analiza structurală a unei macarale Nr. 98/06.10.2011, S.c. AL VAC Romania S.R.L. Lugoj Ammount: 2666 RON. E.Ghita, A. Cernescu, Luisa Dungan.

##### PUBLISHED PAPERS

1. Mihaela Herman Methodes de formation en moderne versus devouement Sesiunea Euroregionala de Comunicări „ Pași spre un învățământ de calitate” Ediția VI, Timișoara, Ed. Eurostampa, pag. 93 – 98.

##### PhD STUDENTS

*PhD supervisor: Prof.dr.eng. habil Ioana Ionel:*

Ph.D.student Ramon BALOGH

#### RESEARCH TEAM

10. Assoc. prof.dr. eng. Eugen GHITA
  11. Assoc. prof.dr. eng. Georgeta Emilia MOCUȚA
  12. Lect.dr.eng. Mihaela HERMAN
  13. Lect. dr.eng. Gabriel URUSU-NEAMT
  14. Lect. dr.eng. Luiza-Izabel DUNGAN
- Ph.D.student Dan STEPAN  
 Ph.D.student Ramon BALOGH

#### CONTACT

Assoc. prof. dr. eng. Eugen Ghita  
 ([eugen.ghita@mec.upt.ro](mailto:eugen.ghita@mec.upt.ro))

Faculty of Mechanical Engineering  
 1 Mihai Viteazul Bv.  
 Timișoara, RO-300222, Romania  
 Tel.: +40-256-403725

**Researches in URBAN TRANSPORTATION,  
ROAD TRAFFIC SAFETY, ROAD TRAFFIC  
CONTROL, INTELIGENT TRANSPORT  
SYSTEMS AND ENVIRONMENTAL  
PROTECTION**

**Keywords:** planning, design, road traffic, control, monitoring, simulation,

**ACTIVITIES**

Road traffic management

Planning, design, and optimization of road freight and passengers transport;

Road safety an environment impact studies

Usage and maintenance of supervision, control, monitoring, automation equipment and of road traffic directing, means

Intelligent Transport Systems

**RESULTS**

**PUBLISHED PAPERS**

1. Werner Ștefănescu Patrick Ștefănescu Some aspects of urban transport and consumption of public space Sesiunea Euroregionala de Comunicări „ Pași spre un învățământ de calitate” Ediția VI, Timișoara, Ed. Eurostampa, pag. 89 – 94.
2. Patrick Ștefănescu Werner Ștefănescu Internal and external environmental analysis at RATT Timisoara Sesiunea Euroregionala de Comunicări „ Pași spre un învățământ de calitate” Ediția VI, Timișoara, Ed. Eurostampa, pag. 91 – 96.

**PERSPECTIVES**

Development of the laboratory for telematics in transportation

**Phd STUDENTS**

*Phd Supervisor Prof.dr.eng.Ion DANILA*

1. Eng. Cristian MINCA: *Studies on tyre – road interaction in particular motion conditions;*
2. Eng. Lucian IRIMIE: *Contributions to the improvement of vehicle maneuverability;*
3. Eng. Alin PEIA: *Research on technical analysis of road accidents;*
4. Werner BIRCHAM: *Contribution to the improvement of the fodder plant harvesters*
5. Eng. Remus URSULESCU: *Contribution to the improvement of the constructive and functional parameters of the wheels tractors .*

**RESEARCH TEAM**

- Prof.dr.eng. Ion DANILA- cons.prof
- Assoc.prof.dr.eng. Dumitru IANCULUI
- Lect.dr.eng. Attila GONCZI
- Lect.dr.eng. Werner STEFANESCU
- Lect.dr.eng. Ionel VANDICI
- Lect. dr.eng. Adrian CIPLEU
- Assist. eng. Remus URSULESCU
- Ph. D. Student Lucian IRIMIE

**CONTACT**

Lect. dr. eng. Werner STEFANESCU  
[it@mec.upt.ro](mailto:it@mec.upt.ro): [wstefanescu@mpt.utt.ro](mailto:wstefanescu@mpt.utt.ro)

Faculty of Mechanical Engineering  
1 Mihai Viteazul Bv.  
Timișoara, RO-300222, Romania

Tel.: +40-256-403720  
Fax: +40-256-403520

## RESEARCH CENTER IN STRENGTH OF MATERIALS AND SAFETY OF MECHANICAL STRUCTURES, CABLES AND CONDUCTORS

### RESEARCH AREAS

- Fatigue and Fracture Mechanics
- Behaviour of composite materials at static loading and fatigue, cracking mechanism, plates behaviour at dynamic loading
- Life-time prolongation of steels at high temperatures
- Accuracy of solutions involved in the stress calculus of curved specimens
- Physical properties of aluminium, steel-aluminium and steel conductors
- Wire and wire ropes and round steel chains
- High temperature behaviour of steels, stability and creep of long vertical pipes, curved beams stress analysis
- Analysis and tests about behaviour of materials belonging of heavy devices being out of working life-time
- Numerical analysis and simulation of stress response of different structures

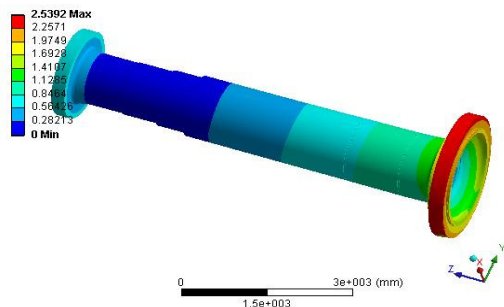

### KEYWORDS

Wohler's curve, fatigue crack propagation, crack closure, displacement at crack opening, computer tests, life – time, fracture tenacity, stress intensity coefficient  $K_{IC}$ ,  $J$  – integral, fatigue at variable deformation, cumulative degradation at variable loading, macroscopically aspects at fatigue fracture, dynamic fatigue, safety and risk, probabilistic aspects of fatigue and fracture mechanics, defects toleration, conductors, stress, strain, modulus of elasticity, creep, ambient temperature, thermal properties, term elasticity, thermal fatigue, fracture, pipes under pressure, composite materials, fatigue, dynamical, loads, composite plots.

### FIELD DESCRIPTION

Endurance of Steel wire ropes and round steel chains, service and fatigue life, stress - strain, bending, ropes and chains for cranes and other hoisting or transporting machines.

Stress - Strain Test. Curves equations for initial composite, steel and aluminium, final composite, steel and aluminium.

Studies concerning the life-time prolongation of steels at high temperatures, studies about the accuracy of solutions involved in the stress calculus of curved specimens. Researches can be used by electro technical materials industry and distributing electrical energy units. There are also useful in order to participate to international auctions.

Studies concerning the behaviour of composite materials at static loading and fatigue, cracking mechanism, plate's behaviour at dynamic loading.

Analysis the influence of in-service conditions for different types of steel belonging to minning equipments being out of working life-time. There were performed some researches regarding the behaviour at variable loads, impacts and also fracture mechanics analysis.

Creep at ambient temperature tests of aluminium and steel-aluminium conductors in order to certify their quality. The loading and unloading behaviours are described by typical diagrams and equations of curves have been estimated. Experimental researches were performed at ambiental and results were extra poled beginning 100 or 1000 hours to 10000 hours.



### ACTIVITIES

- The life – time estimation of some strength elements (wire ropes, links, springs, etc) at imposed loading levels
- The strength at fatigue estimation of some steel and welded elements
- The analysis of the influence of simulated defects about the fatigue strength at welded elements
- The estimation of  $K_{IC}$  and  $J_{IC}$  for some machine parts steels
- The estimation of the dynamic tenacity coefficients  $K_{Idc}$  and  $J_{Idc}$
- The analysis of crack propagation at cyclic loading and under repeated shocks
- Estimation of mechanical characteristics obtained at variable loads
- Computer programme analysis for durability of a bar belonging to a heavy minning machine, by using fracture mechanics theory
- Design devices for hanging cracking pipes
- Theoretical and experimental studies of vertical long specimens under compressive loading also into account thermal effects.

### RESEARCH TEAM

- Prof.dr.eng. Nicolae NEGUȚ
- Prof.dr.eng. Ion DUMITRU
- Prof.dr.eng. Nicolae FAUR
- Prof.dr.eng. Pavel TRIPA
- Prof.dr.eng. Liviu MARȘAVINA
- Prof.dr.eng. Tiberiu BABEU
- Prof.dr.eng. Constantin CRISTUINEA
- Assoc.prof.dr.eng. Dana SILAGHI PERJU
- Lect.dr.eng. Marcela SAVA
- Lect.dr.eng. Mihai HLUȘCU
- Lect.dr.eng. Nicolaie CIOBOTARU
- Assist.eng. Iuliu SISAK
- Assist.eng. Radu NEGRU
- Eng. Anghel CERNESCU
- Eng. Cristian NEȘ
- Eng. Emanoil LINUL
- Eng. Dan Andrei ȘERBAN
- Eng. Lorand KUN
- Eng. Adrian BIRLAN

### RESEARCH OFFERS

Bending endurance testing, Tensile fatigue testing, Experimental stress analysis, Fatigue prediction, Research on wires, Standards (ISO-TC 85), Stress-strain, Breaking test, Creep at ambient temperature test for 6 month, 1 year, 10 years creep;

Study – test for composite materials, Stress concentration and fatigue, Composite materials structures computation;

Expert study of equipment for heavy machines with expired life-time, Fracture mechanics testing, Fatigue with impact, Non-destructive testing;

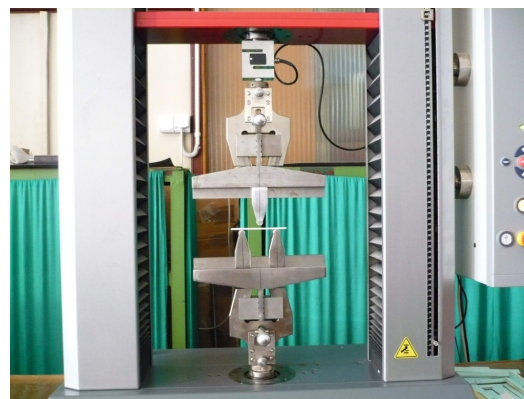

High Temperature Study of Creep Properties; Theoretical Analysis and Creep Computation for pipes Stability and Creep for vertical long pipes.

### RESEARCH CONTRACTS

1. FP7 ERG 230991, Reliability of Interfaces in Composite Materials, CE, Marsavina Liviu, Faur Nicolae, 6458 EURO
2. BC 50/04.04.2011, *FEA for thermoplast housing*, Project Manager: Cernescu Anghel, Beneficiary: SC HELLA Romania SRL, Value: 2124,4 RON
3. 61/04.05.2011, *Shear and Tensile Tests for welded wires netting used in reinforced concrete*, Project Manager: Cernescu Anghel, Beneficiary: SC ATON Transilvania SRL, Value: 2905 RON
4. 657/15.05.2007, *Testing of dynamometers for cables tensioning*, Project Manager: Faur N., Nes C., Linul E., Kun L., Cernescu A., Beneficiary: SC Electro Montaj Carpați Sibiu, Value: 2000 RON
5. 99/29.09.2009, *Stress-Strain test of Al 60.76 mm<sup>2</sup> conductor, type DC30 – Enel and Fracture testing of Al 60.76 mm<sup>2</sup> conductor, type DC30 – Enel*, Project Manager: Faur N., Nes C., Linul E., Kun L., Cernescu A., Beneficiary: SC ELECTROPLAST S.A, Value: 2400 RON
6. PN-II-ID-PCE-2011-3-0456, *Micro-mechanical modelling of the cellular materials behaviour*, CNCS, Marsavina Liviu, 81000 RON

### DOCTORAL STUDIES

#### PhD THESIS

1. Linul Emanoil, *Mechanical Characterisation of Cellular Materials*, PhD coordinator: Liviu Marsavina, 12.09.2011
2. Nes Cristian Sorin, *Research on fracture mechanics parameters evaluation by numerical methods*, PhD coordinator: Nicolae Faur, 12.09.2011

#### PhD THEMES

Scientific supervisor: Prof.dr.eng. Ion Dumitru:

1. Branzei Nelu Florin, *Fatigue analysis study of steel railway couplings used for transportation*.
2. Cotuna Emil, *Study of stability elastic elements of the traducers of load*.

Scientific supervisor: Prof.dr.eng.Nicolae Faur:

1. Enkelhardt Angelica, *Stent optimisation studies*.
2. Birlan Adrian, *Research on thermal fields optimisation in plastic injection processes*.

Scientific supervisor: Prof.dr.eng.Liviu Marsavina:

1. Serban Dan, *The Fatigue behaviour of polymers*.
2. Palade Adrian, *Fretting Fatigue simulation*.
3. Ailinei Ionut, *Durability of solder joints*.
4. Pasca Niculae, *Integrity and Durability of hidroagregates*.

## PUBLICATIONS

### PAPERS

1. Cernescu A., Faur N., Bortun C., Hluscu M., - *A methodology for fracture strength evaluation of complete denture*, Engineering Failure Analysis, vol. 18(5), p. 1253-1261, ISSN 1350-6307, 2011;
2. Cernescu A., Faur N., Bortun C., Nes C.- *Fatigue crack growth rate in acrylic resins under variable amplitude loadings*, Theoretical and Applied Fracture Mechanics, vol. 56, p. 58-61, ISSN 0167-8442, 2011;
3. Bortun C., Ghiban B., Ghiban A., Cernescu A., Ghiban N., Semenescu A.- *Comparative studies of tensile and bending behavior for some CoCrMo alloys*, Metalurgia International, vol. 16(7), p. 5 – 13, ISSN 1582 – 2214, 2011;
4. Chincea I., Cernescu A., Marsavina L., Serban V.A.- *Fatigue damage evolution in laminate composites with balsa wood*, Cellulose Chemistry and Technology, vol. 45(5-6), p. 421- 426, ISSN 0576-9787, 2011;
5. Şerban D.A., Marşavina L., Silberschmidt V.; *Behaviour of semi-crystalline thermoplastic polymers: Experimental studies and simulations*, Computational Materials Science, 139-146 (8 pagini), ISSN 0927-0256;
6. Linul E., Marsavina L., *Influence of geometrical parameters on fracture toughness for open cell foams*, 20th International Conference Computer Methods in Mechanics, Warsaw, POLONIA, 9-12 Mai, Proceedings of 20th International Conference Computer Methods in Mechanics, pg. 443-444, ISBN 978-83-7207-943-5
7. Neş C.S., Faur N., Marşavina L., *Numerical analysis of crack angle and crack interaction influence on stress intensity factors*, Acta Technica Napocensis, Series: Applied Mathematics and Mechanics, No. 53, Vol. II, 2010, pg. 213-218, ISSN 1221 – 5872
8. Neş C.S., Faur N., Marşavina L., *Numerical analysis of crack interaction influence on crack propagation*, Buletinul Universităţii Petrol-Gaze din Ploieşti, Seria Tehnica, Buletinul Universităţii Petrol-Gaze din Ploieşti, Seria Tehnica, LXIII (1), 73-82, ISSN 1224-8495
9. Linul E., Marsavina L., *Experimental determination of compressive properties for rigid polyurethane foams*, Buletinul Universităţii Petrol-Gaze din Ploieşti, Seria Tehnica, Buletinul

Universităţii Petrol-Gaze din Ploieşti, Seria Tehnica, LXIII (1), 199-204, ISSN 1224-8495

10. Sadowski T., Marsavina L., *Multiscale modelling of two-phase ceramic matrix composites*, Computational Material Science, 50(4), 1336-134, ISBN 0927-0256

11. Marsavina L., Nurse A.D., *Comparison between elastic-perfectly-plastic interfacial free-edge and crack tip singular fields*, Strojnicki Vestnik/Journal of Mechanical Engineering, 57(1), 40-46, ISBN 0039-2480

12. Marsavina L., Sadowski T., Faur N., *Numerical investigation of the stress field near a crack normal to ceramic-metal interface*, Journal of Mechanical Science and Technology, 25(2), 309-315, ISBN 1738-494X

13. Marsavina L., Linul E., *Prediction of fracture toughness for open cell polyurethane foams by finite-element micromechanical analysis*, Iranian Polymer Journal, 20(9), 735-746, ISBN 1026-1265

14. Faur N., Marsavina L., Cernescu A., Nes C.S., Linul E., *The Influence of the Steel and Aluminium Components Separation at the Conductors Locking for Stress-Strain Tests*, Key Engineering Materials, Vol. 417-418, pp. 693-696, ISBN 978-0-87849-315-9

15. Sinescu C., Negrutiu M.I., Ionita C., Marsavina Liviu, Negru R., Topala F., Petrescu E., Rominu R., Fabriky M., Bradu A., Rominu M., Podoleanu A. G., *Biomedical implications of dental ceramic defects investigated by numerical simulation, radiographic, microcomputer tomography and time domain optical coherence tomography*, Conference on Optical Complex Systems, Marseille, FRANTA, Proc. SPIE, Vol. 8172, pp.8172-07, ISBN 978-0-81948-798-8

## PERSPECTIVES

The researches in the fields of fatigue and fracture mechanics present a topical interest. The implementation of new equipments in the laboratory of fatigue and fracture mechanics and the inclusion of the laboratory as a part of the National Research Centre in Construction and Fatigue, BCUM, code CNCSIS 19, will allow the extension of the researches to new directions and will offer the opportunity to solve any request in this field.

A special attention will be granted to new materials, and also to traditional materials with unknown mechanical characteristics regarding the fatigue behaviour.

## CONTACT

Prof.dr.eng. Nicolae FAUR  
Faculty of Mechanical Engineering  
Blvd. Mihai Viteazu, nr. 1, 300223 Timișoara  
Tel: +40-256-403577  
Fax: +40-256-403572  
E-mail: [faur@mec.upt.ro](mailto:faur@mec.upt.ro)



# MECHANICAL MACHINES, TECHNOLOGY AND TRANSPORTATION

## – MECHANICAL TECHNOLOGY DEPARTMENT

### GENERAL PRESENTATION AND MISSION

The *Mechanical Technology Department(TM)* is organized within the Department of Mechanical Machines, Technology and Transportation (MMUT). TM department is organized as a research unit and transfer of technology of the “Politehnica” University of Timișoara.

Mission is to coordinate teams of researchers from TM department of the Faculty of Mechanical Engineering, who are developing programs in the specific field of research.

### RESEARCH FIELDS

The main fields of research are:

- Products, processes and manufacturing systems integrated design;
- Processes and manufacturing systems integrated management;
- Products and manufacturing devices new models design;
- Integrated Design of products, manufacturing processes and systems;
- Quality evaluation of the manufacturing processes and systems;
- New products and manufacturing equipment;
- The development of the equipments and technologies for non-conventional technological processes
- development and application of optimized materials processing technologies, with energy concentrated, laser, inkjet fluids, electrical erosion
- Studies referring to the development of modern constructive solutions for making of technological equipment from the processional and food industry
- The creation and the making of piezoceramic traducers for the usage in the construction of technological equipment
- Evaluation of degradation of the materials used in technologies equipment and the calculation of the remaining durability of exploitation
- Optimizing metallic flexible pipes processing

### KEYWORDS

Integrated engineering, Concurrent engineering, Manufacturing engineering, Manufacturing processes management, Quality assurance, Equipment and technologies for non-conventional technological processes, Laser materials processing, Plan and equipment for food industry, Piezoceramic traducers, Degradation of materials, remaining durability of exploitation.

### ACTIVITIES

TM department assure the co-ordination and harmonization of the training programs through scientifically research (PhD. programs, post-graduated programs) for the researchers or research teams of different departments. The MASTER program developed is:

- Engineering labor relations, safety and health work
- Quality management process technology
- Integrated food manufacturing systems
- Integrated Food Manufacturing
- Manufacturing optimization of process equipment

The PhD. programs coordinated are in the field of Mechanical Engineering and Industrial Engineering. In the advanced doctoral training program UPT prof. PhD, eng. Nichici Alexandru, coordination of the teaching component of the course and direction of cross-discipline seminars: Objectives, strategies and methods in scientific research, Scientific communication and deontology.

- The research teams from TM department develop: fundamental and applicative research activities; products and technology design activities; technological development and technology transfer all attending the present industrial demands.
- TM department is involved in national and international research programs, is member of different professional and scientifically organizations and organizes different scientific meetings (seminars, conferences etc.).
- Participation to the EC Sixth Framework Program (FP6) and EC Seventh Framework Program (FP7) as a partner/coordinator to a network of excellence project.
- Participation to grant competitions through CNCISIS, ANCS national programs, structural funds.
- Developing of fundamental and applicative research activities, technological development for the present industrial demands.
- TM department members are part of the following professional bodies and associations: SPIE –Internat. Society for Optical Technologies  
ASM – American Material Society  
BENA – Balkan Environmental Association  
ISL-FD – International Society of Lyophilization-Freeze Drying  
AGIR – The General Association of the Engineers in Romania  
ARTN – Romanian Association of Nonconventional Technologies

ASR – Romanian Welding Society  
 ACM-V – Association for Multidisciplinary  
 Research West Zone

#### RESEARCH CONTRACTS

1. Project IP ERASMUS, Materials, Energy and Sustainable Growth 09-ERIP-06862-05060\_02 ERASMUS Ammount: 14989.5 euro, Team members: Nicolae Crainic, Dinu Gubencu
2. Imbunatatirea Managementului Universitar POSDRU 2/1.2/S/4 POSDRU, Ammount: 61200, Team members: Diana Andone, Nicolae Muntean, Aurel Gontean, Daniel Grecea, Daniel Vizman, Crainic Nicolae
3. Școala universitară de formare inițială și continuă a personalului didactic și a trainerilor din domeniul specializărilor tehnice și inginerești”, DidaTec POSDRU/86/1.3/S/60891 POSDRU Ammount: 250656,6, Team members: VasIU Radu, Andone Diana, Mocofan Muguras, Toma Dragomir, Serban Viorel, Alexa Florin, Ternauciuc Andrei, Bodin Florin, Lascu Dan, Dragomir Mugur, Grecea Carmen, Holotescu Carmen, Bogdanov Ivan, Ionel Sabin, Toth-Tascau Mirela, Crainic Nicolae, Muntean Nicolae, Grecea Daniel, Onița Mihai, Gontean Aurel, Dragulescu Bogdan, Bucos Marian, Tanase Delia, Mihaescu Vlad, Vert Silviu, Ermalai Iasmina

#### Prospective:

- Participation to the EC Seven Framework Program (FP7)
- Participation to grant competitions through national programs, sectorial program and direct international contract.

#### PUBLICATIONS

##### BOOKS

1. Fleser T., Ionel, Ioana, Vetres, I.(ed.) Proc. at 35<sup>th</sup> Cong. American Romanian Academy of Arts and Sciences (ARA): Science and Art in the Informatics Era Proc. Conf. Presses Internationales Polytechnique, Montreal ISSN 978 – 2 – 553 –01596– 0.

##### PUBLISHED PAPERS

1. Bidi L., Mattei Simone, Cicala E., Andrzejewski H., Le Masson P., Schroeder Jeanne, The use of exploratory experimental designs combined with thermal numerical modelling to obtain a predictive tool for hybrid laser/MIG welding and coating processes, Optics & Laser Technology vol. 43 pag. 537-545.
2. Elena Maria Mosoarca, I. Pantenburg, Ramona Tudose, G. Meyer, NC Popa, Adelina Han, Radostina Alexandrova, R. Kalfin, W.

Linert, Otilia Costisor Synthesis, structure and cytotoxic activity of mixed-valent Cu(I)/Cu(II) salt containing a pyrazolone derivative as ligand, Inorganica Chimica Acta, Volume 370, Issue 1, pag 460-468.

3. Tucu D.; Hollerbach W. Analyze of opportunities for willow's culture as biomass ressources in Banat region, Actual Tasks on Agricultural Engineering-Zagreb, Volume: 39, p. 171-178.
4. Herman L.; Tucu D. Integration of renewable sources of energy in an independent farm, Actual Tasks on Agricultural Engineering-Zagreb Volume: 40 p. 179-187.
5. Golimba Antonio-Gabriel; Tucu Dumitru Considerations on optimizing the palletizing systems of agricultural products using robotics elements, Actual Tasks on Agricultural Engineering-Zagreb Volume: 41 p. 367-373.
6. Botiș Mihaela A comparative analysis between sodium silicate and the admixture solution used in complex erosion, Revista de Tehnologii Neconvenționale, The 15-th International Conference Non-Conventional Technologies, ICNcT, 3-5 Nov, Arad, 2011 vol.3/19-22/4.
7. V. Safta, P. Fogarassy, V.I. Safta, Analiza numerică a vârfurilor de tehnsiune la principalele îmbinări sudate de colț, Revista SUDURA vol. 21/2011, pag. 11-16.
8. Tulcan Liliana, Tulcan A. Particular phenomenon into the work space of the ultrasonic aided abrasive lapping, Revista de tehnologii neconventionale/ Nonconventional technologies review Vol XV,Nr.4, p. 59 – 62.
9. Tulcan Liliana, Tulcan A. Ultrasonic emulsification in the food industry, Buletinul AGIR supliment /2011 Sisteme integrate pentru productia agroalimentara supliment 2011, 247 – 250.
10. Groza I. Experimental modeling of electrode-tool wear when processing aloed steels through electrical erosion, Buletinul AGIR supliment /2011 Sisteme integrate pentru productia agroalimentara supliment 2011, p. 194 – 197.
11. Nanu A. Perspectives of Nonconventional Technologies, Revista de tehnologii neconventionale/Nonconventional technologies review vol XV,Nr.3, p. 5 – 8.
12. Boboescu R. Effects of energy level of irradiation for laser welding, Revista de tehnologii neconventionale/Nonconventional technologies review vol XV,Nr.3, p. 9 – 14.
13. Boboescu R. Analytical model for weld depth in laser welding, Revista de tehnologii neconventionale /Nonconventional technologies review vol XV,Nr.4, p. 15 – 20.



14. Mnerie, F. Molnar-Matei, A. Nanu, T. Slavici, D. Mnerie Particular aspects of modern automation of electrical erosion machine with wire electrode, *Revista de tehnologii neconventionale / Nonconventional technologies review* vol XV,Nr.3, p. 47 – 50.
15. Lilijana Dukici Petromanja, Gabriela Victoria Mnerie, D. Mnerie New smart metering systems, *Revista de tehnologii neconventionale / Nonconventional technologies review* vol XV,Nr.4, p. 68 – 72.
16. Crisan C., Mnerie D., Tucu D. Management features of safety and occupational health applied in integrated systems for agro-food production, *Buletinul AGIR supliment /2011 Sisteme integrate pentru productia agroalimentara supliment 2011* p. 22 – 25.
17. Gusetoiu Ramona Ionela, Smaranda A. Muskoskeletal disorders in agriculture, *Buletinul AGIR supliment /2011 Sisteme integrate pentru productia agroalimentara supliment 2011* p. 36 – 39.
18. Iancu Anca, Tucu D., Damacus G. Study of rheological properties of gluten-free flours with the chopin mixolab, *Buletinul AGIR supliment /2011 Sisteme integrate pentru productia agroalimentara supliment 2011* p. 51 -53.
19. Smaranda A., Tucu D. Different industrial applications of lignin as a sustainable material, *Buletinul AGIR supliment /2011 Sisteme integrate pentru productia agroalimentara supliment 2011* p. 115 – 118.
20. Tucu D., Hollerbach W. The use of eucalyptus oil for wireworms control in energetic willow crops, *Buletinul AGIR supliment /2011 Sisteme integrate pentru productia agroalimentara supliment 2011* p. 137 – 140.
21. Damacus G., Iancu Anca, Tucu D. Optimization of lamination proces. The penetration of food packaging by lamination adezives components, *Buletinul AGIR supliment /2011 Sisteme integrate pentru productia agroalimentara supliment 2011* p. 170 – 174.
22. Lilijana Dukici Petromanja, Mnerie Gabriela Victoria, D. Mnerie Optimizing electricity distribution in rural areas, *Buletinul AGIR supliment /2011 Sisteme integrate pentru productia agroalimentara supliment 2011* p. 179 – 183.
23. Iancu Anca, Tucu D., Damacus G. Studies on the behavior of gluten-free pasta to boiling, *Buletinul AGIR supliment /2011 Sisteme integrate pentru productia agroalimentara supliment 2011* p. 197 – 199.
24. Mnerie Gabriela Victoria, D. Mnerie Concerns regarding corroded metals microstructure found in contact with food during freeze drying process, *Buletinul AGIR supliment /2011 Sisteme integrate pentru productia agroalimentara supliment 2011* p. 223 – 226.
25. Smaranda A., Gusetoiu Ramona Ionela Analysis of biodegradable agricultural films and opportunities of use, *Buletinul AGIR supliment /2011 Sisteme integrate pentru productia agroalimentara supliment 2011* p. 233 – 235.
26. Mnerie D., Mnerie Gabriela Victoria Management strategies in food production in integrated current european context, *Buletinul AGIR supliment /2011 Sisteme integrate pentru productia agroalimentara supliment 2011* p. 328 – 331.
27. Tucu D, Smaranda A., Rotarescu V., Condescu M. Life costs in analyse of opportunities for willow's culture as biomass ressource in Banat region, *Buletinul AGIR supliment /2011 Sisteme integrate pentru productia agroalimentara supliment 2011* p. 363 – 369.
28. Szuhaneck Camelia, Fleşer T. A matehematical study regarding forces effects during orthodontic treatment, *Proc. 22-the International DAAAM symposium, 23-26.XI.2011, Vienn.* p. 329 – 330.
29. Pop-Calimanu,M., Fleser, T. Application of process welding at aluminium matrix composites, *Scientific Bulletin of Politehnica University of Timisoara, Mechanical series Tom 56 (70), fasc. 4, p.23-28.*
30. Botiş Mihaela, Gubencu D. Studies of mild steel corrosion in acid solutions, *Buletinul ştiinţific al U.P.T, seria Mecanica vol.56/70/ p. 1-4.*
31. Szuhaneck, Camelia, Fleser, T. Mechanical properties of ceramic orthodontic brackets, *Proc. at 35<sup>th</sup> Cong. American Romanian Academy of Arts and Sciences (ARA), Timisoara, iuly, 2011 Edit. Presses Internationales POLIYTECHNIQUE, Montreal . Quebec p. 204 – 207.*
32. Szuhaneck, Camelia, Fleser, T. Mechanical characteristics of aesthetic nitinol archwires, *Proc. at 35<sup>th</sup> Cong. American Romanian Academy of Arts and Sciences (ARA), Timisoara, iuly, 2011 Edit. Presses Internationales POLIYTECHNIQUE, Montreal . Quebec p. 200 – 203.*
33. Szuhaneck, Camelia, Fleser, T. Biomechanical analysis of Two closing Spaces Methods, *Proc. at 35<sup>th</sup> Cong. American Romanian Academy of Arts and Sciences (ARA), Timisoara, iuly, 2011 Edit. Presses Internationales POLIYTECHNIQUE, Montreal . Quebec p.125 – 128.*
34. Pop-Calimanu, M., Fleser, T. Characteristic of joining aluminium matrix composites, *Proc. at 35<sup>th</sup> Cong. American Romanian Academy of*

- Arts and Sciences (ARA), Timisoara, iuly, 2011 Edit. Presses Internationales POLYTECHNIQUE, Montreal . Quebec p.163 – 166.
35. Szuhaneck, Camelia, Fleser, T. Thermo-mechanical modeling of jointing process by friction stir welding of aluminium-based composites materials, Proc. the 4th International Conference on Advanced Materials and Structures - AMS '11, Timisoara, oct. 2011 Editura POLITEHNICA Timisoara, p.74 – 75.
  36. Szuhaneck, Camelia, Fleser, T. Research on welded thin NiTi wires and orthodontic bands, Proc. the 4th International Conference on Advanced Materials and Structures - AMS '11, Timisoara, oct. 2011 Editura POLITEHNICA Timisoara, p. 32 – 33.
  37. Tulcan, A., Cioană, C., Stan, D., Tulcan Liliana, Bernath, A. Modular design of a coordinate measuring system, The 4th International Conference of Manufacturing Engineering ICMEN, Thessaloniki, Greece, 3-5 October, 2011 Proceeding of 4<sup>th</sup> International Conference of Manufacturing Engineering ICMEN p. 181 – 186.
  38. Crainic N, Doina Bica, Antonio Torres Marques, Vekas L., Paulo Jorge Novoa, Oana Marinica, Nuno Correia, Pedro Vieira, Carlos Pinto Moreira de Sa Applications des nanofluides magnetiques dans la science des materiaux nanocomposites magnetisables, Xeme Colloque Franco - Roumain sur les Polymeres, Douai, France, 6 - 8 Septembre, 2011 Abstracts Book 2.
  39. Crainic Nicolae, Antonio Torres Marques, Nicolae Calin Popa, Paulo Jorge Novoa, Oana Marinica, Nicolae Calin Popa, Nuni Correia, Alina Taculescu, Patricia Peerz, Camelia Daia Particularitie Concerning the Influence of the Magnetic Nanofluids in the Fabrication Process of the Nanocomposite Materials, ICCS16 - 16TH International Conference on Composite Structures, Porto, Portugal, 28 - 30 June CD 2.
  40. Ramona Laslău, R. Boboescu Analysis of specifica areas on laser welds cross-section, AFASES 2011 A 13-a conferință internațională cu tema “Cercetare științifică și educație în forțele aeriene”, Academia forțelor aeriene “Henri Coandă” Brașov. 2011 Lucrările conferinței AFASES 2011 p. 895-900.
  41. Ramona Laslău, R. Boboescu Laser Beam defocusing effectson laser welds, AFASES 2011 A 13-a conferință internațională cu tema “Cercetare științifică și educație în forțele aeriene”, Academia forțelor aeriene “Henri Coandă” Brașov. 2011 Lucrările conferinței AFASES 2011 p. 901-906.
  42. Boboescu R. Analysis of conditions for obtaing a keyhole regime for laser welding, The 16th International Conference “New technologies and products in machines manufacturing tehnologies 2011-Universitatea “Ștefan cel Mare” Suceava Tehnomus 2011 p. 69-76.
  43. Boboescu R. Aplication of full factorial design experiments for laser welding, The 16th International Conference “New technologies and products in machines manufacturing tehnologies 2011-Universitatea “Ștefan cel Mare” Suceava Tehnomus 2011 p. 215-222.
  44. Boboescu R. Aplicații ale experimentelor de tip factorial pentru efectele defocalizării în sudarea laser, A 5-a conferință internațională “Tehnologii inovative pentru îmbinarea materialelor avansate” ISIM Timișoara iunie 2011.
  45. Boboescu R. Linear mathematical models for welds in laser welding, The 22st International Conference NAV-MAR-EDU 2011 Editura Academiei Navale „Mircea cel Bătrân” Constanța Section 2 Mechanical Engineering Proceedings of the 22st International Conference NAV-MAR-EDU 2011 p. 35-46.
  46. Boboescu R. Analysis of dynamic aspects of steel pieces melting in laser welding, The 22st International Conference NAV-MAR-EDU 2011 Editura Academiei Navale „Mircea cel Bătrân” Constanța Section 2 Mechanical Engineering Proceedings of the 22st International Conference NAV-MAR-EDU 2012 p. 47-59.

#### AWARDS

TM Department team has coorganizator of international conferences.

#### PhD THESIS

In Department Mechanical Technology the following is the list of thesis supervisor: Prof. dr.dhc. eng. Nanu Aurel, Prof. Ph.D. Nichici Alexandru, Prof. Ph.D. Popovici Vasile, Prof. Ph.D. Sporea Ioan, Prof. Ph.D. Fleser Traian, Prof. Ph.D. Tucu Dumitru, Assoc. prof. Ph.D. Eugen Cicală.

#### PhD Students

In 2011the following PhD thesis was supported in public:

1. Antonio-Gabriel GOLIMBA Contributii la optimizarea sistemelor automate de ambalare a produselor agroalimentare, PhD supervisor Prof.dr.ing. Dumitru TUCU.

**RESEARCH TEAM**

TM department consists of research teams with common and separate concerned research projects. The human resources consist of researchers which are doctor degree graduates or which leads post-graduates programs. Also, in the team are working post-graduates and master students.

The TM department management is assured by the leader and the Scientific Council, which is composed of professors or associate professors that have been recognized for their research activity and results.

The Scientific Council is composed of the research team leaders.

The members of the research team are:

- Professor Ph.D. Richard Herman
- Prof. Ph.D. Traian Fleşer
- Prof. Ph.D. Dumitru Mnerie
- Prof. Ph.D. Dumitru Țucu
- Prof. Ph.D. Mihai Ghiță
- Prof. Ph.D. Titus Slavici
- Prof. Ph.D. Ioan David
- Assoc. prof. Ph.D. Nicolae Crainic
- Assoc. prof. Ph.D. Mircea Olariu
- Assoc. prof. Ph.D. Eugen Cicală
- Assoc. prof. Ph.D. Nistoran Botis Mihaela
- Assoc. prof. Ph.D. Antoniu-Levay Reviczky
- Assoc. prof. Ph.D. Mircea Vasilescu
- Lect. Ph.D. Tulcan Liliana
- Lect. Ph.D. Traian Botea
- Lect. Ph.D. Voicu Safta
- Lect. Ph.D. Gabriel Malaimare
- Lect. Ph.D. Dinu Gubencu
- Lect. Ph.D. Ioan Groza
- Lect. Ph.D. Adelina Han

**CONTACT**

Prof.dr.eng. Herman Richard –  
TM Department leader  
Bul. Mihai Viteazu, nr. 1  
300223, Timișoara, Romania  
Tel/fax: +40-256-403583  
Fax: +40-256-403589  
Web: <http://www.tm/mec.upt.ro>  
E-mail: richard.herman@mec.upt.ro

